

ambient countertops • self help service



Image: VOACT2



Image: VOACT3



| Stock Code | Overall Size | Weight | Wattage |
|------------|--------------------------|--------|---------|
| | mm | kg | kw |
| VOACT2 | 825(w) x 660(d) x 627(h) | 60 | 0.3 |

| Stock Code | Overall Size | Weight | Wattage |
|------------|---------------------------|--------|---------|
| | mm | kg | kw |
| VOACT3 | 1175(w) x 660(d) x 627(h) | 70 | 0.3 |

- Ambient countertop food display for self help service.
- Ideal for confectionery, crisps, fruit etc.
- Customer access via three hinged acrylic flaps.
- Produce displayed on two removable glass shelves and base level.
- Illumination to all display levels.
- Fixed back as standard. Rear doors not available for this display.

technical specifications



VOACT2

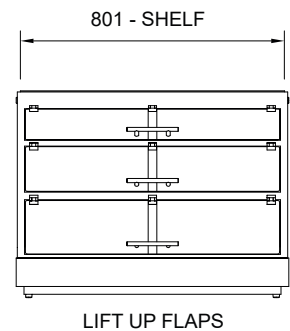
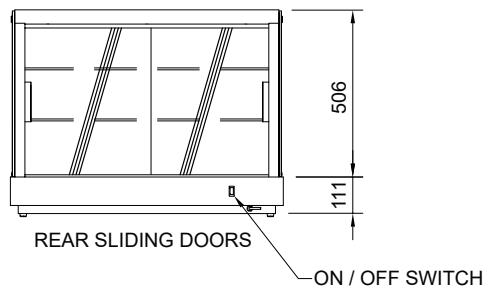
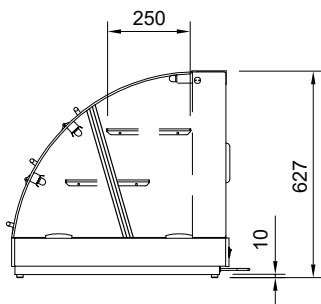
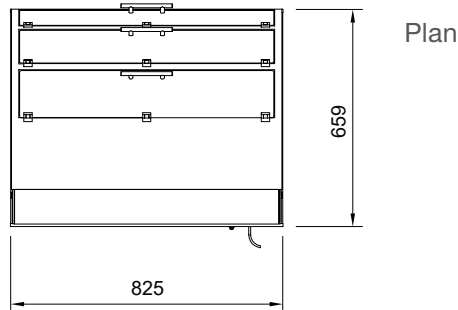

VOACT3

