

manhattan • chilled display well



Image: MHDL4-GO



Stock Code	Capacity (gn)	Overall Size (mm)	Weight (kg)	Wattage (kw)
MCW2-GO	2/1	825 x 660 x 560h	91	1.4
MCW3-GO	3/1	1175 x 660 x 560h	108	1.7
MCW4-GO	4/1	1525 x 660 x 560h	128	1.9
MCW5-GO	5/1	1875 x 660 x 560h	141	1.9
MCW6-GO	6/1	2225 x 660 x 560h	158	2.2

- Flat bed chilled well, which is perfect for the display of salads, drinks and fruit.
- Gentle flow of convected air maintains pre-chilled food at a safe regulated temperature.
- The angle of the display deck can be adjusted for enhanced presentation.
- Gantry mounted controller installed on operators side (GO) as standard.
- The gantry controller can be installed on customer side (GC) on request.
- A wide range of optional extras are available for this display.

technical specifications

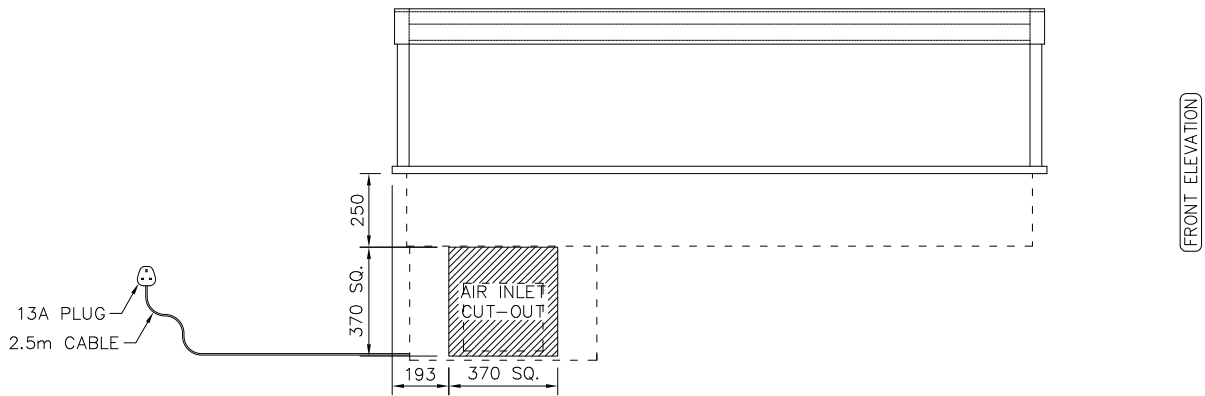

(FRONT ELEVATION)

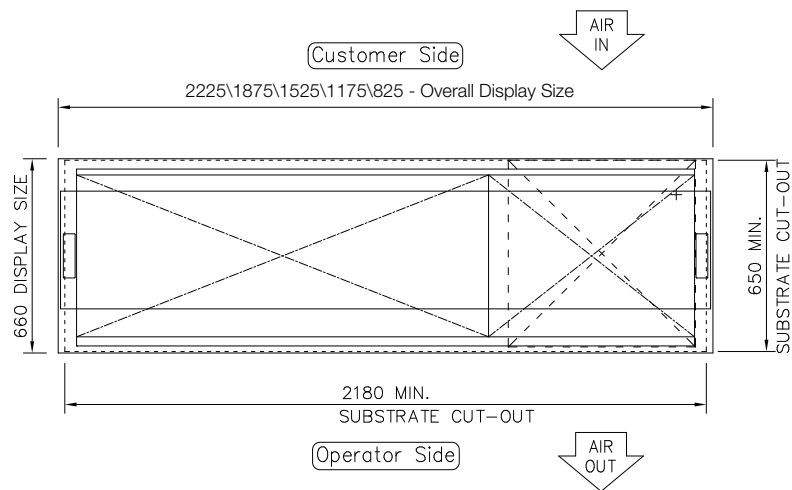

(PLAN VIEW)

NOTE:
 IF DISPLAY IS TO BE FLUSH
 MOUNTED INTO WORKTOP,
 ADD 4 - 6mm TO DISPLAY
 SIZES FOR WORKTOP CUT-OUT

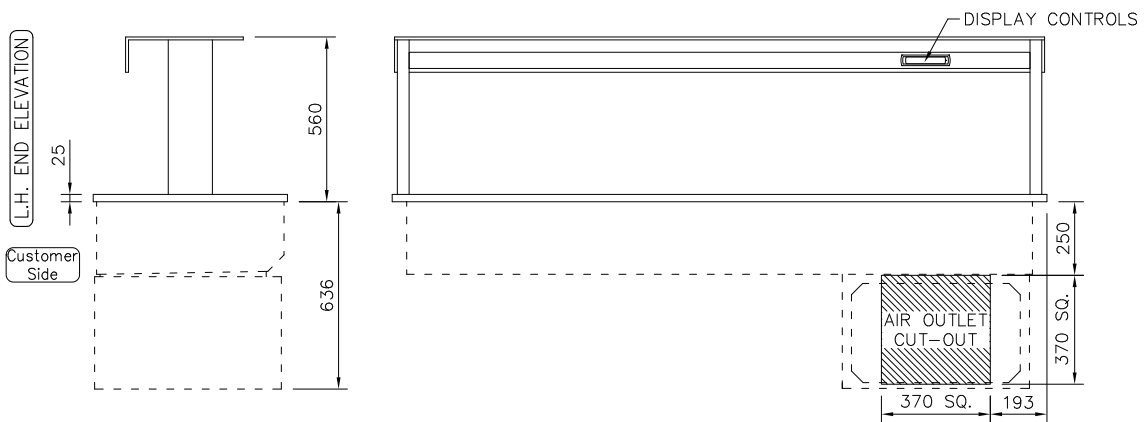

(REAR ELEVATION)