

integrale • heated display deli



Image: IHDL4-GO



Stock Code	Capacity (gn)	Overall Size (mm)	Weight (kg)	Wattage (kw)
IHDL2-GO	2/1	825 x 660 x 535h	44	1.2
IHDL3-GO	3/1	1175 x 660 x 535h	60	1.8
IHDL4-GO	4/1	1525 x 660 x 535h	76	2.4

- Fully enclosed heated display deli designed for assisted service only.
- This display deli maintains pre-heated, cooked food at a regulated temperature.
- Base display area is angled towards the customer for optimum food presentation.
- Gantry mounted controller installed on operators side (GO) as standard.
- A wide range of optional extras are available for this display.

technical specifications

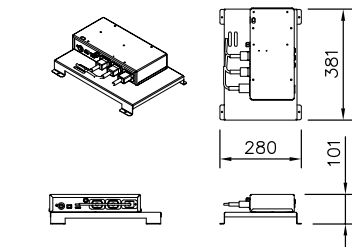

DISPLAY POWER BOARD DETAILS

FOR FURTHER DETAILS PLEASE REFER TO THE HEATED INSTALLATION DETAILS

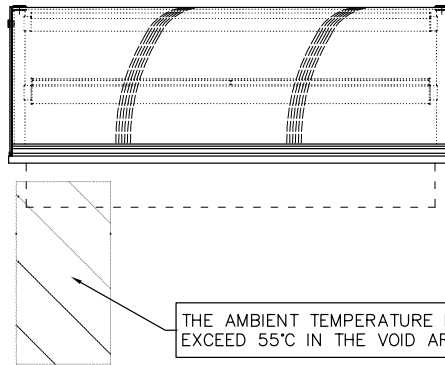

FRONT ELEVATION

THE AMBIENT TEMPERATURE MUST NOT EXCEED 55°C IN THE VOID AREA INDICATED.

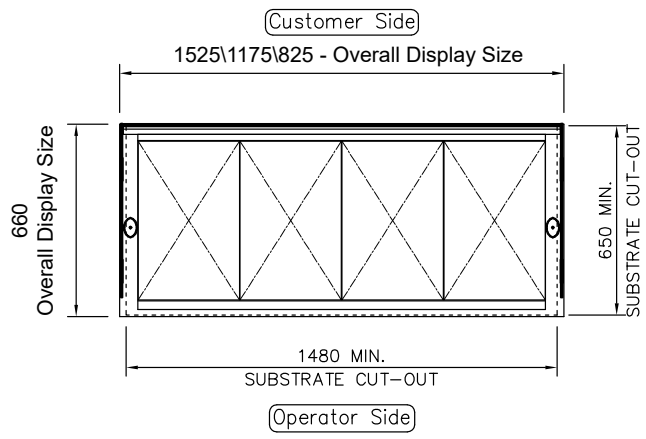

PLAN VIEW

NOTE:
 IF DISPLAY IS TO BE FLUSH MOUNTED INTO WORKTOP, ADD 4 - 6mm TO DISPLAY SIZES FOR WORKTOP CUT-OUT

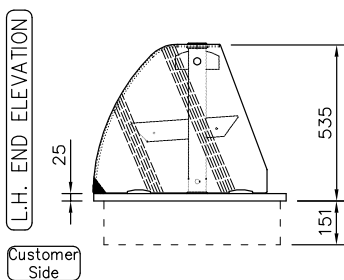

Customer Side

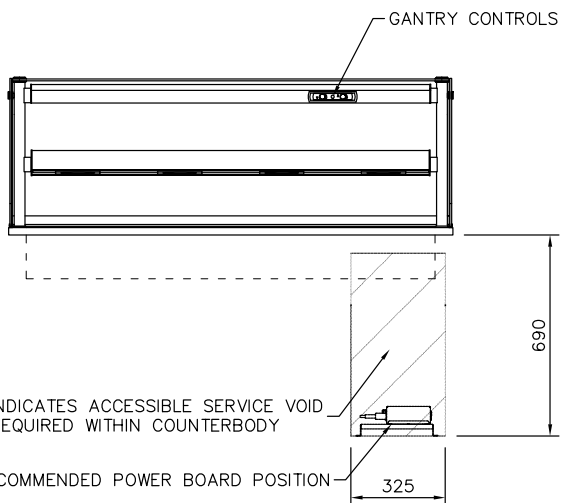

REAR ELEVATION

INDICATES ACCESSIBLE SERVICE VOID REQUIRED WITHIN COUNTERBODY
 RECOMMENDED POWER BOARD POSITION