

integrale • chilled display deli



Image: ICDL4-GO



Stock Code	Capacity (gn)	Overall Size (mm)	Weight (kg)	Wattage (kw)
Chilled Deli				
ICDL2-GO	2/1	825 x 764 x 535h	103	1.4
ICDL3-GO	3/1	1175 x 764 x 535h	125	1.7
ICDL4-GO	4/1	1525 x 764 x 535h	153	1.9
ICDL5-GO	5/1	1875 x 764 x 535h	183	1.9
ICDL6-GO	6/1	2330 x 764 x 535h	197	2.2
Chilled Wide Deli				
ICWDL2-GO	2/1	825 x 914 x 535h	105	1.4
ICWDL3-GO	3/1	1175 x 914 x 535h	126	1.7
ICWDL4-GO	4/1	1525 x 914 x 535h	158	1.9
ICWDL5-GO	5/1	1875 x 914 x 535h	190	1.9
ICWDL6-GO	6/1	2330 x 914 x 535h	197	2.2

- Fully enclosed chilled display deli designed for assisted service only.
- Gentle flow of convected air maintains pre-chilled food at a safe regulated temperature.
- Rear preparation shelf with optional chopping board.
- The angle of the display deck can be adjusted for enhanced presentation.
- The centre shelf is for the display of ambient produce.
- Gantry mounted controller installed on operators side (GO) as standard.
- New 2-tier version available on special request.

technical specifications

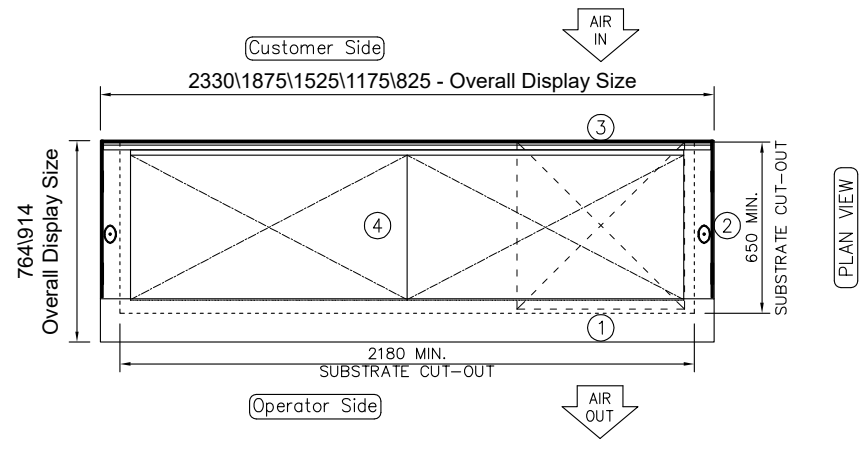
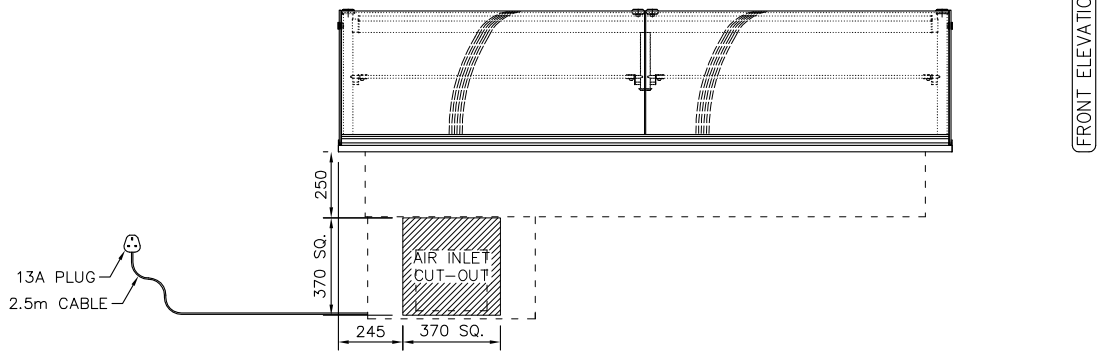

NOTE:
 IF DISPLAY IS TO BE FLUSH
 MOUNTED INTO WORKTOP,
 ADD 4 - 6mm TO DISPLAY
 SIZES FOR WORKTOP CUT-OUT

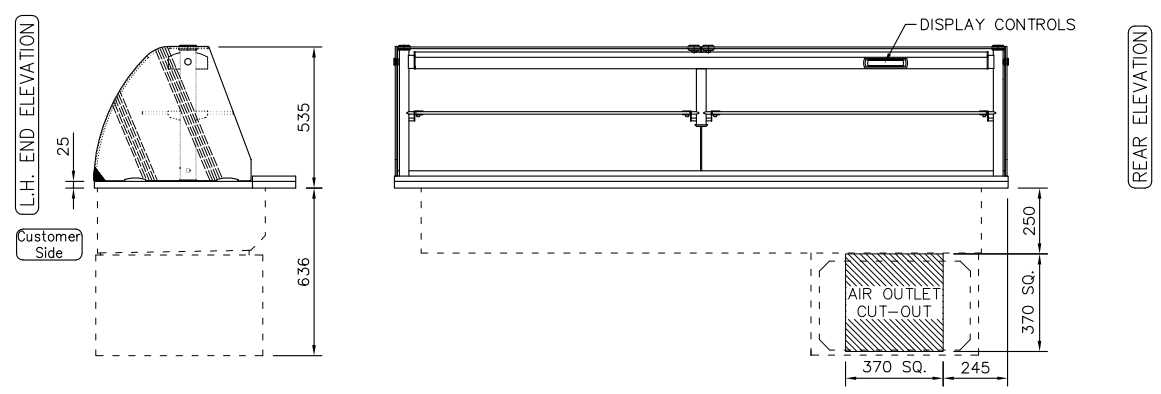

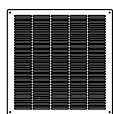
 CUSTOMER & OPERATOR SIDE FASCIA
 PANELS MUST BE REMOVABLE FOR
 MAINTENANCE ACCESS
 SUPPLIED WITH 400mm SQ. STAINLESS
 STEEL AIR INLET/OUTLET GRILLES