

END ELEVATION

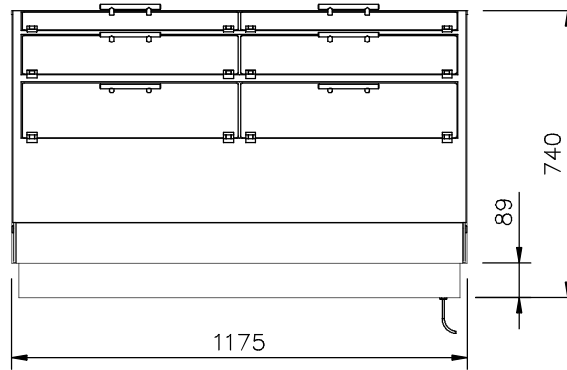

PLAN VIEW

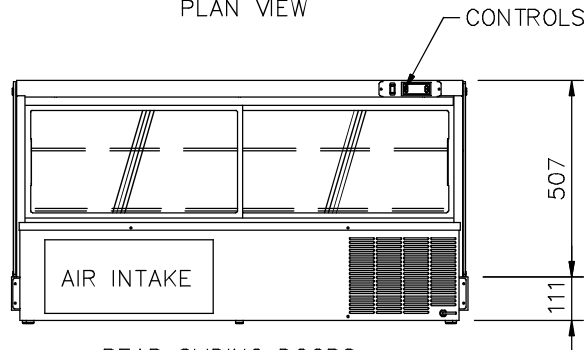

REAR SLIDING DOORS

REAR ELEVATION

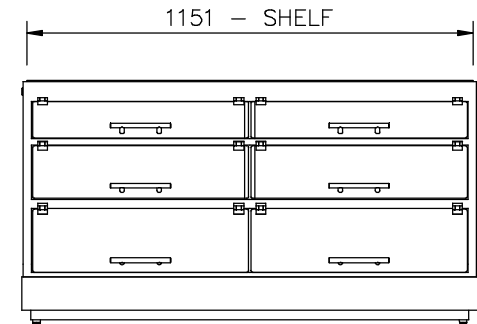

LIFT UP FLAPS

FRONT ELEVATION

DISPLAY SUPPLIED WITH 1500mm LEAD & PLUGTOP

DISPLAY HAS INTEGRAL CONDENSATE EVAPORATOR

ELECTRICAL INFO: 13A, 230V

WEIGHT: 83Kg

PRODUCT RANGE: COUNTERTOP VISION  
DESC.: CHILLED ENCLOSED SELF HELP  
COUNTERTOP DISPLAY

OPTION:

ID CODE: VOCCT3

**counterline** 

RANDES RD, KNOWSLEY BUSINESS PARK, MERSEYSIDE L34 9HZ.

Tel: 0151 548 2211

Fax: 0151 549 2179

ISSUE:

1

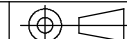

SCALE: 1:20 @ A4