

PLAN VIEW

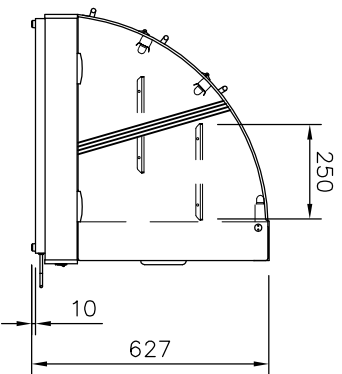

END ELEVATION

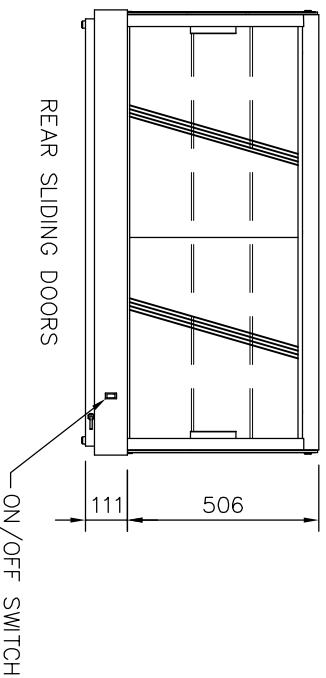

REAR ELEVATION

REAR SLIDING DOORS

ON/OFF SWITCH

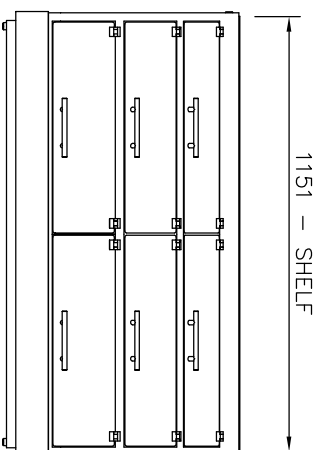

FRONT ELEVATION

LIFT UP FLAPS

1151 - SHELF

DISPLAY SUPPLIED WITH 1500mm LEAD & PLUGTOP

ELECTRICAL INFO: 13A, 230V

WEIGHT: 70Kg

PRODUCT RANGE: COUNTERTOP VISION
 DESC.: AMBIENT ENCLOSED SELF HELP
 COUNTERTOP DISPLAY

OPTION:

ID CODE:

VOACT3

counterline

RANDES RD, KNOWSLEY BUSINESS PARK, MERSEYSIDE L34 9HZ.

Tel: 0151 548 2211

Fax: 0151 549 2179

ISSUE:

1

SCALE: 1:20 @ A4