

A

B

C

D

E

F

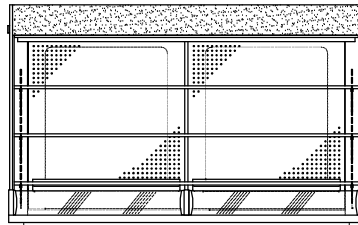

FRONT ELEVATION

13A PLUG  
2.5m CABLE

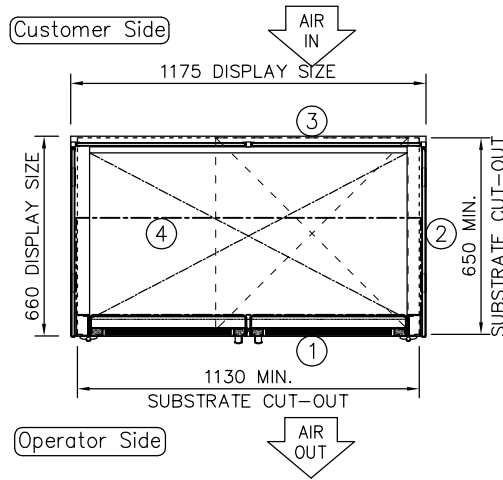
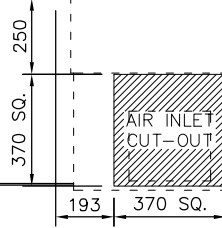

PLAN VIEW

NOTE:  
IF DISPLAY IS TO BE FLUSH  
MOUNTED INTO WORKTOP,  
ADD 4 - 6mm TO DISPLAY  
SIZES FOR WORKTOP CUT-OUT

L.H. END ELEVATION

Customer Side

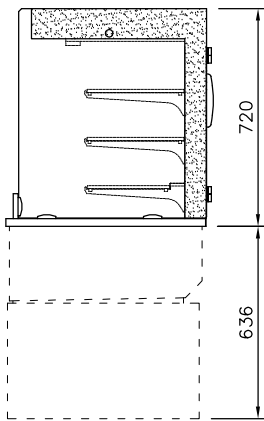

REAR ELEVATION

DISPLAY CONTROLS

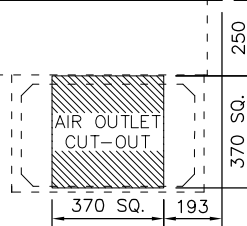
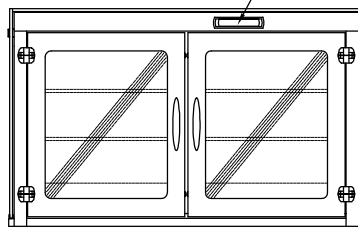

CUSTOMER & OPERATOR SIDE FASCIA  
PANELS MUST BE REMOVABLE FOR  
MAINTENANCE ACCESS  
SUPPLIED WITH 400mm SQ. STAINLESS  
STEEL AIR INLET/OUTLET GRILLES

PRODUCT RANGE: idesign  
DESC.: 3-1Gn SELF HELP COLD MULTIDECK  
3 TIER ADJUSTABLE SHELF+DOORS  
OPTION: INTEGRAL REFRIGERATION (3-1)

**counterline** 

RANDLES RD, KNOWSLEY BUSINESS PARK, MERSEYSIDE L34 9HZ.

Tel: 0151 548 2211

Fax: 0151 549 2179

ID CODE: MC3ASMD3-GO

ELECTRICAL INFO: 13A, 230V, 2.8KW

WEIGHT: 161Kg

ISSUE: 1

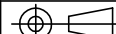

SCALE: 1:25 @ A4