

A

B

C

D

E

F

FRONT ELEVATION

PLAN VIEW

REAR ELEVATION

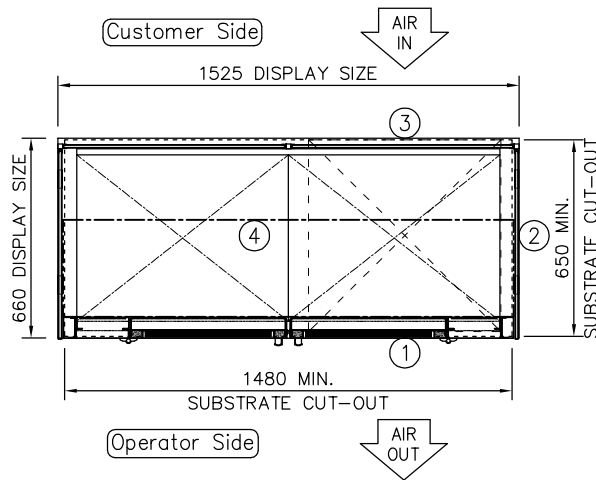
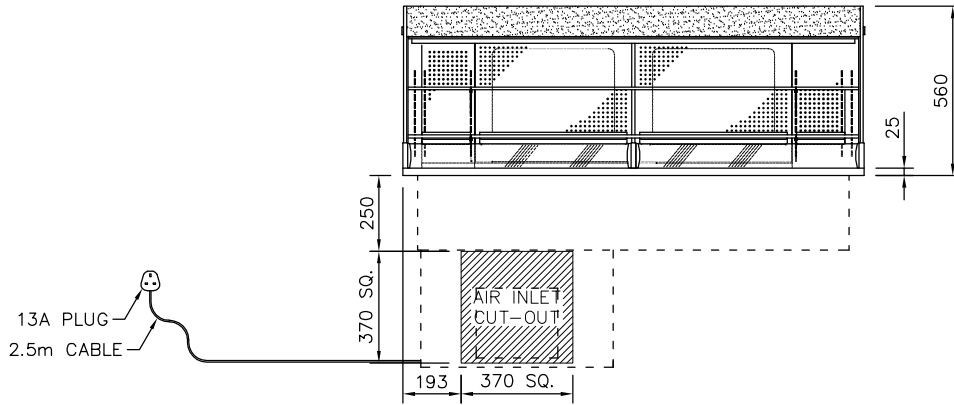

NOTE:
IF DISPLAY IS TO BE FLUSH
MOUNTED INTO WORKTOP,
ADD 4 - 6mm TO DISPLAY
SIZES FOR WORKTOP CUT-OUT

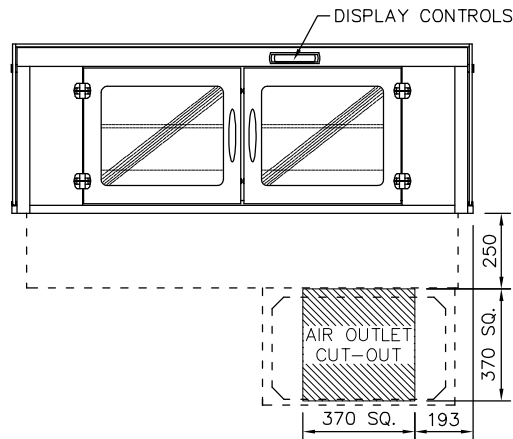
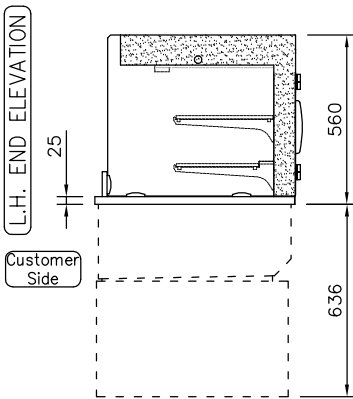

CUSTOMER & OPERATOR SIDE FASCIA
PANELS MUST BE REMOVABLE FOR
MAINTENANCE ACCESS
SUPPLIED WITH 400mm SQ. STAINLESS
STEEL AIR INLET/OUTLET GRILLES

PRODUCT RANGE: idesign
DESC.: 4-1Gn SELF HELP COLD MULTIDECK
2 TIER ADJUSTABLE SHELF+DOORS
OPTION: INTEGRAL REFRIGERATION (3-1)

ID CODE: MC2ASMD4-GO
OPTION
CODE:

counterline 

RANDLES RD, KNOWSLEY BUSINESS PARK, MERSEYSIDE L34 9HZ.

Tel: 0151 548 2211

Fax: 0151 549 2179

ELECTRICAL INFO: 13A, 230V, 3.0KW

WEIGHT: 180Kg

ISSUE: 1



SCALE: 1:25 @ A4