

A

B

C

D

E

F

FRONT ELEVATION

PLAN VIEW

REAR ELEVATION

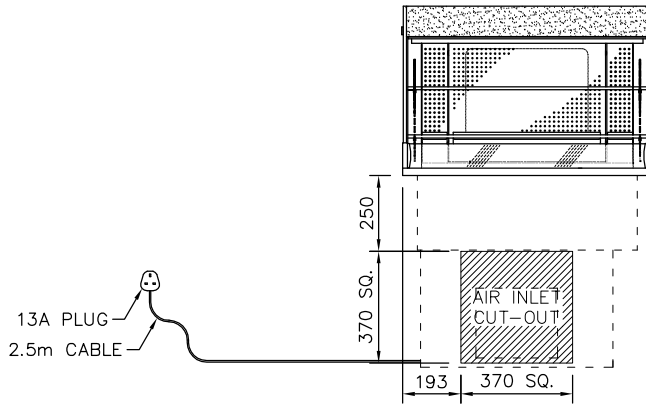

Customer Side

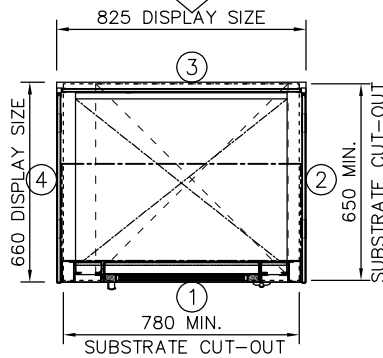

Operator Side



NOTE:  
IF DISPLAY IS TO BE FLUSH  
MOUNTED INTO WORKTOP,  
ADD 4 - 6mm TO DISPLAY  
SIZES FOR WORKTOP CUT-OUT

L.H. END ELEVATION

Customer Side

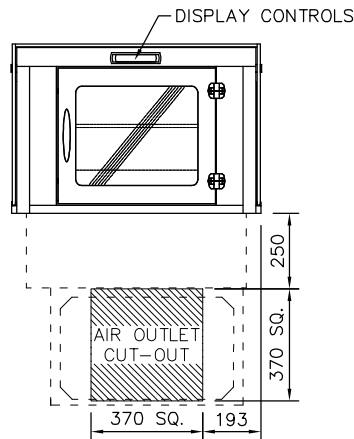
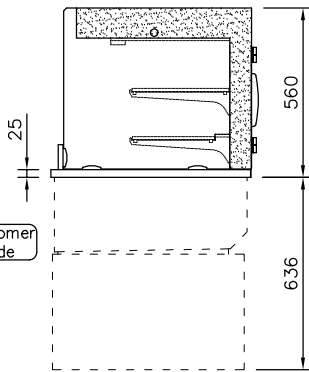

CUSTOMER & OPERATOR SIDE FASCIA  
PANELS MUST BE REMOVABLE FOR  
MAINTENANCE ACCESS  
SUPPLIED WITH 400mm SQ. STAINLESS  
STEEL AIR INLET/OUTLET GRILLES

PRODUCT RANGE: idesign  
DESC.: 2-1Gn SELF HELP COLD MULTIDECK  
2 TIER ADJUSTABLE SHELF+DOOR  
OPTION: INTEGRAL REFRIGERATION (3-1)

ID CODE: MC2ASMD2-GO  
OPTION CODE:

counterline

RANDLES RD, KNOWSLEY BUSINESS PARK, MERSEYSIDE L34 9HZ.

Tel: 0151 548 2211

Fax: 0151 549 2179

ELECTRICAL INFO: 13A, 230V, 2.7KW

WEIGHT: 110Kg

ISSUE: 1



SCALE: 1:25 @ A4