

FRONT ELEVATION

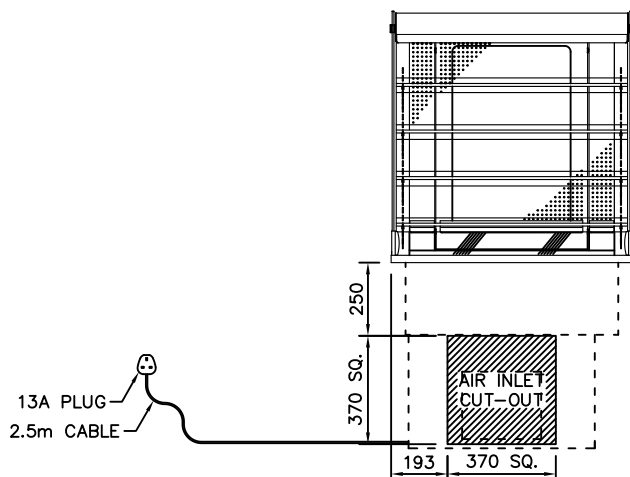

PLAN VIEW

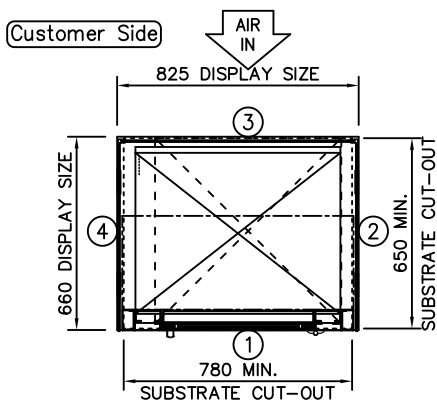

NOTE:
IF DISPLAY IS TO BE FLUSH
MOUNTED INTO WORKTOP,
ADD 4 - 6mm TO DISPLAY
SIZES FOR WORKTOP CUT-OUT

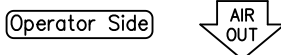

REAR ELEVATION

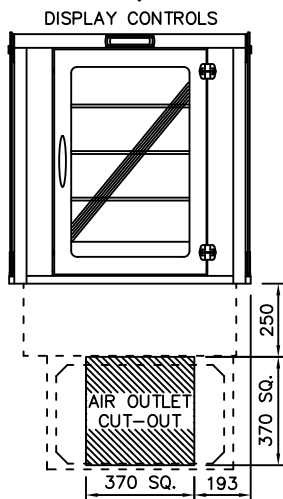

L.H. END ELEVATION

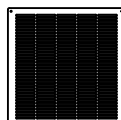
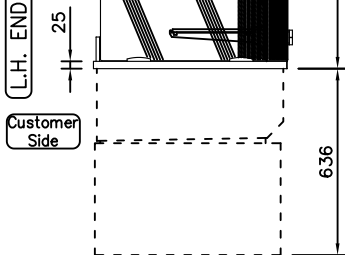

CUSTOMER & OPERATOR SIDE FASCIA
PANELS MUST BE REMOVABLE FOR
MAINTENANCE ACCESS
SUPPLIED WITH 400mm SQ. STAINLESS
STEEL AIR INLET/OUTLET GRILLES

PRODUCT RANGE: idesign
DESC.: 2-1Gn SELF HELP COLD MULTIDECK
4 TIER AJUSTABLE SHELF+DOORS
OPTION: INTEGRAL REFRIGERATION (3-1)

counterline

RANDES RD, KNOWSLEY BUSINESS PARK, MERSEYSIDE L34 9HZ.

Tel: 0151 548 2211

Fax: 0151 549 2179

ID CODE: IC4ASMD2-GO

ELECTRICAL INFO: 13A, 230V, 2.7KW

WEIGHT: 155Kg

OPTION
CODE:

ISSUE:

1

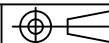

SCALE: 1:25 @ A4