

FRONT ELEVATION

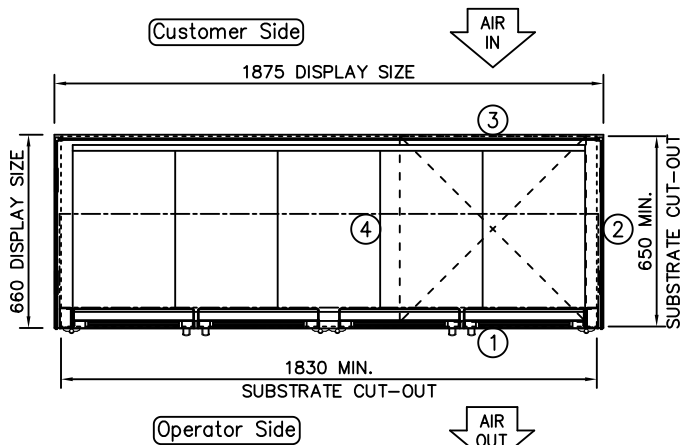

PLAN VIEW

NOTE:
IF DISPLAY IS TO BE FLUSH
MOUNTED INTO WORKTOP,
ADD 4 - 6mm TO DISPLAY
SIZES FOR WORKTOP CUT-OUT

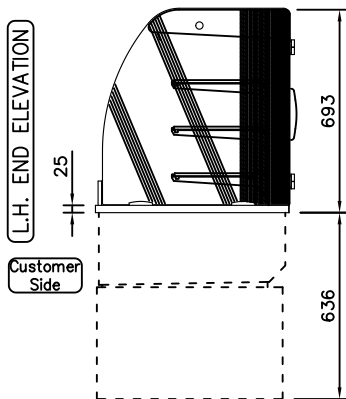

L.H. END ELEVATION

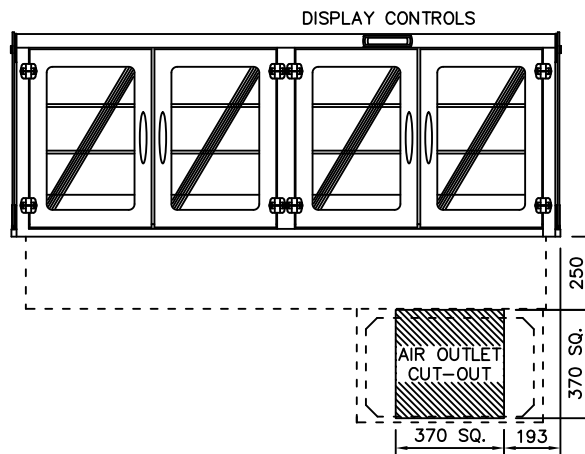

REAR ELEVATION

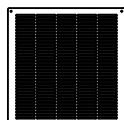

CUSTOMER & OPERATOR SIDE FASCIA
PANELS MUST BE REMOVABLE FOR
MAINTENANCE ACCESS

SUPPLIED WITH 400mm SQ. STAINLESS
STEEL AIR INLET/OUTLET GRILLES

PRODUCT RANGE: idesign
DESC.: 5-1Gn SELF HELP COLD MULTIDECK
3 TIER ADJUSTABLE SHELF+DOORS
OPTION: INTEGRAL REFRIGERATION (3-1)

ID CODE: IC3ASMD5-GO

OPTION
CODE:

counterline 

RANDES RD, KNOWSLEY BUSINESS PARK, MERSEYSIDE L34 9HZ.

Tel: 0151 548 2211

Fax: 0151 549 2179

ELECTRICAL INFO: 16A, 230V, 3.5KW

WEIGHT: 247Kg

ISSUE:

1

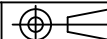

SCALE: 1:25 @ A4