

FRONT ELEVATION

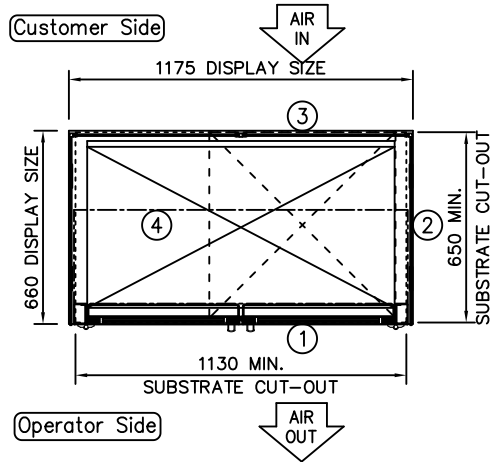

PLAN VIEW

NOTE:
IF DISPLAY IS TO BE FLUSH
MOUNTED INTO WORKTOP,
ADD 4 - 6mm TO DISPLAY
SIZES FOR WORKTOP CUT-OUT

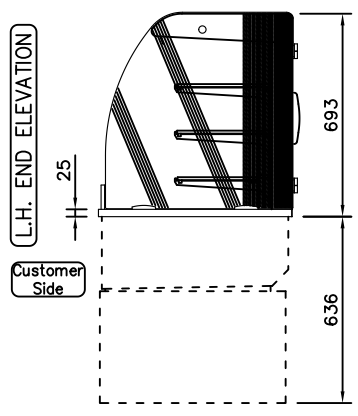

REAR ELEVATION

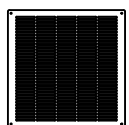
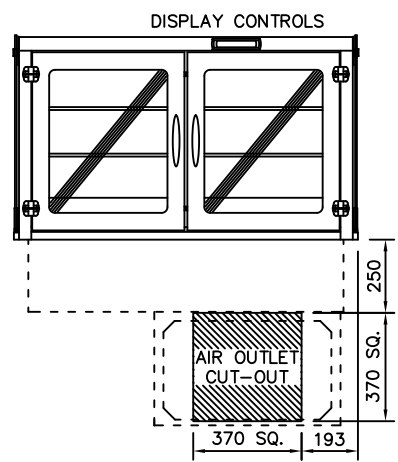

CUSTOMER & OPERATOR SIDE FASCIA
PANELS MUST BE REMOVABLE FOR
MAINTENANCE ACCESS
SUPPLIED WITH 400mm SQ. STAINLESS
STEEL AIR INLET/OUTLET GRILLES

PRODUCT RANGE: idesign
DESC.: 3-1Gn SELF HELP COLD MULTIDECK
3 TIER ADJUSTABLE SHELF+DOORS
OPTION: INTEGRAL REFRIGERATION (3-1)

counterline 
RANGLES RD, KNOWSLEY BUSINESS PARK, MERSEYSIDE L34 9HZ.
Tel: 0151 548 2211 Fax: 0151 549 2179

ID CODE: IC3ASMD3-GO
OPTION CODE:

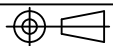
ELECTRICAL INFO: 13A, 230V, 2.8KW WEIGHT: 161Kg
ISSUE: 1  SCALE: 1:25 @ A4