

SECTION A-A

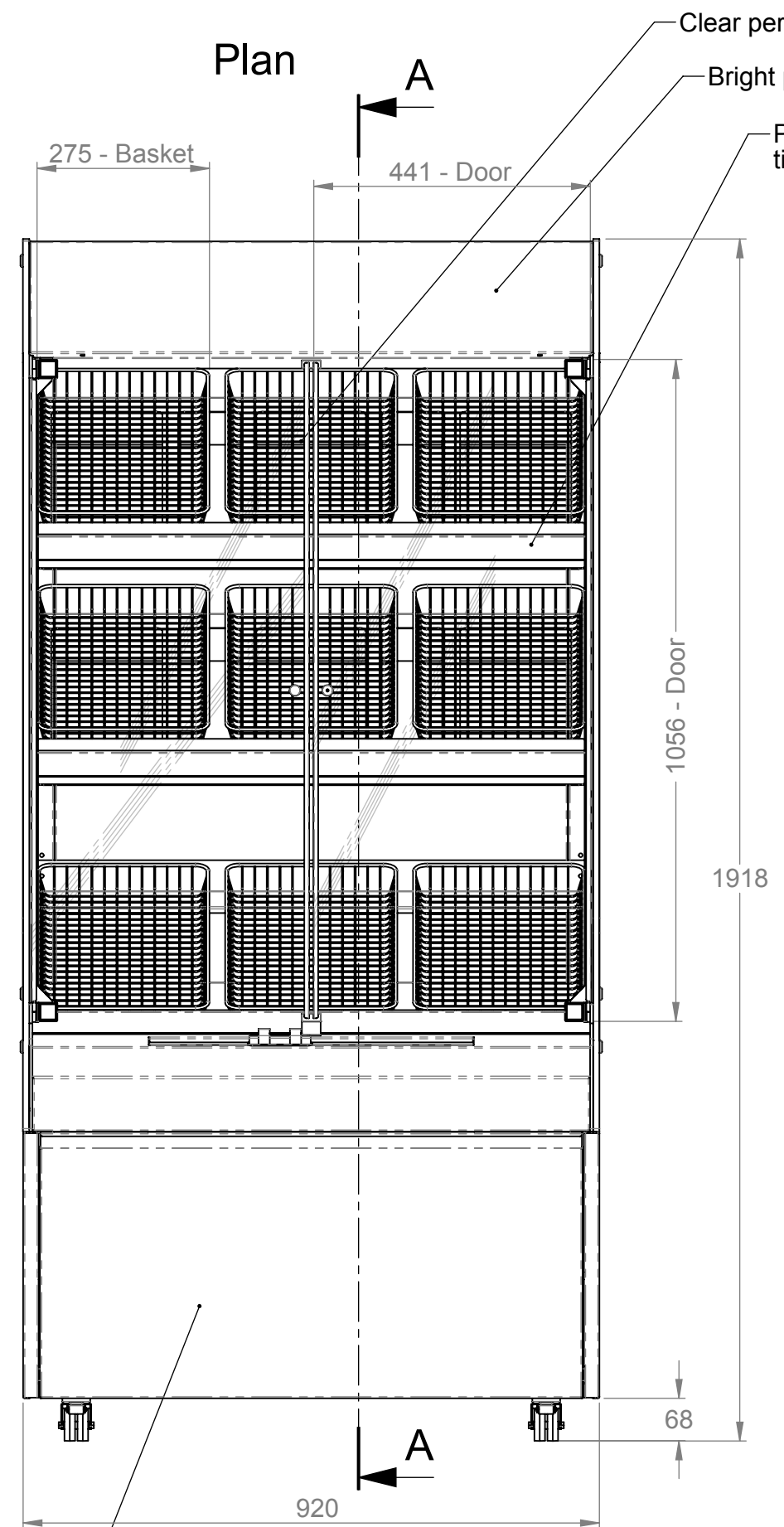

Front elevation

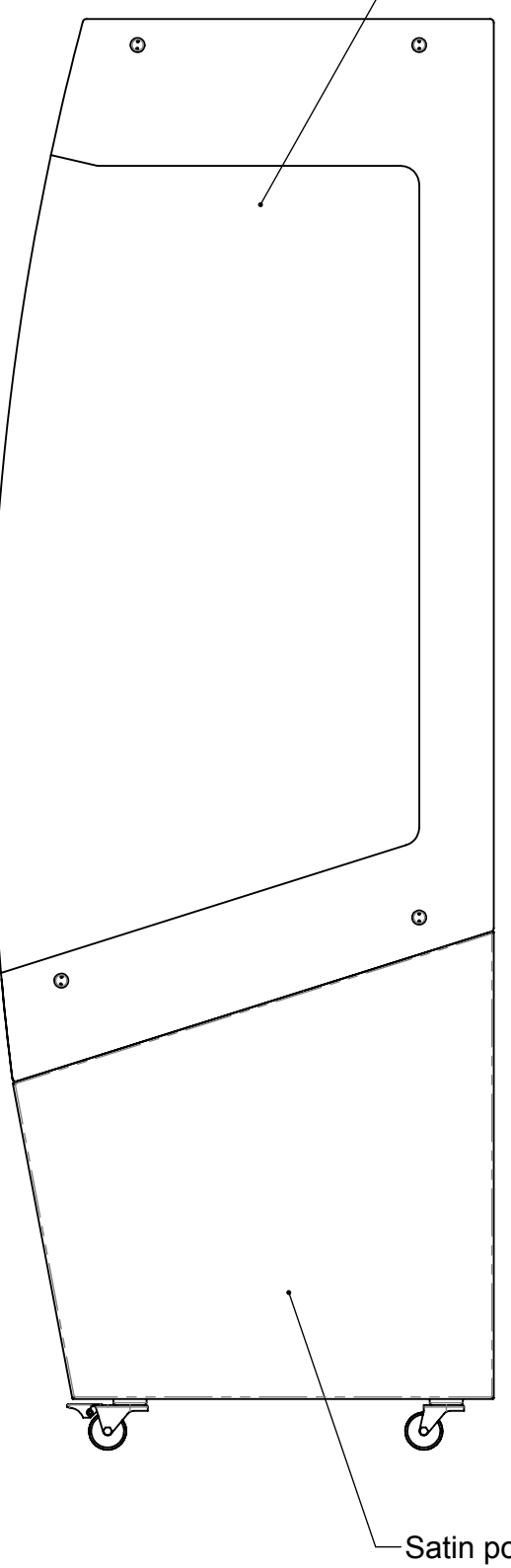

End elevation

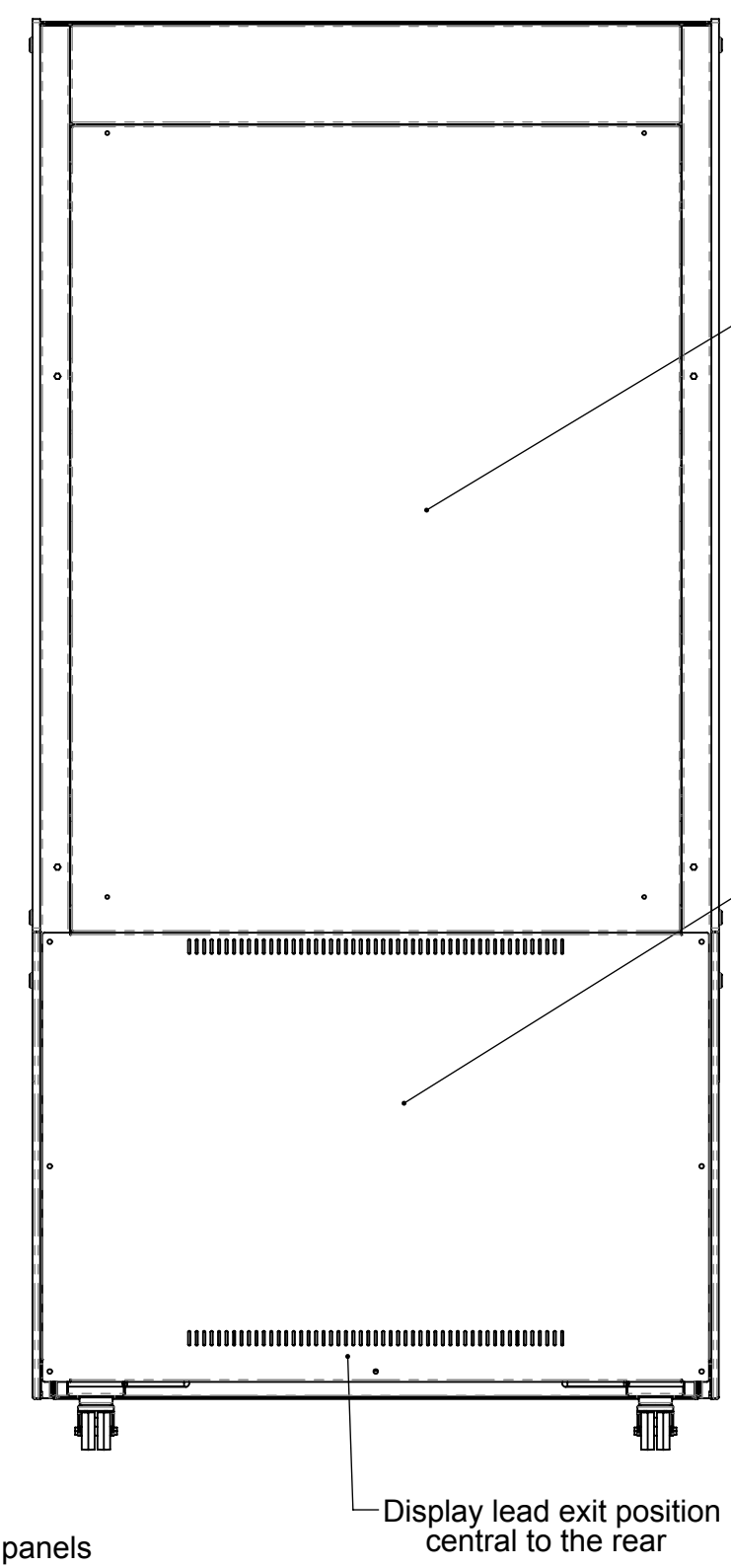

Rear elevation

Electrical info:- 13 Amp 230V 0.2Kw
 Display supplied with 13 Amp on 1500 long lead
 Weight - 120Kg Approx

Assembly No - EA900

Issue	Date	Description
<p>Randles Rd, Knowsley Business Park, Merseyside L34 9HZ. Tel: 0151 548 2211 Fax: 0151 549 2179</p>		
Title: Experience Ambient Display 900		
Drg No :	Issue:	Date: 08/05/2017
17-091--A		Scale: 1:10 @ A2
		Chk'd:
Drn by: G Burgess	All dims in MM	Date: