

1

2

3

A

A

B

B

C

C

D

D

E

E

F

F

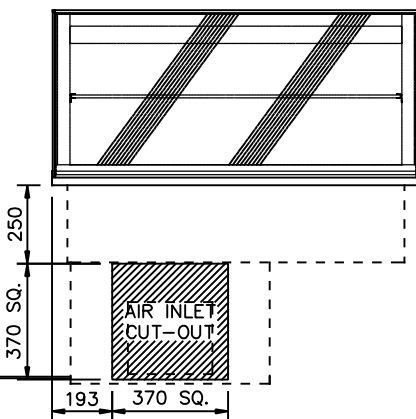
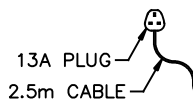

FRONT ELEVATION

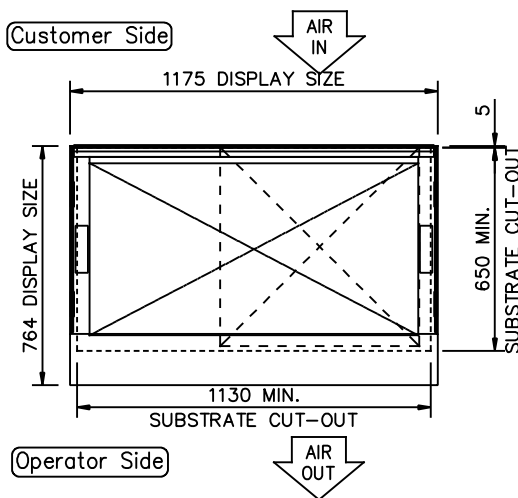

PLAN VIEW

NOTE:
IF DISPLAY IS TO BE FLUSH MOUNTED INTO WORKTOP,
ADD 4 - 6mm TO DISPLAY SIZES FOR WORKTOP CUT-OUT

L.H. END ELEVATION

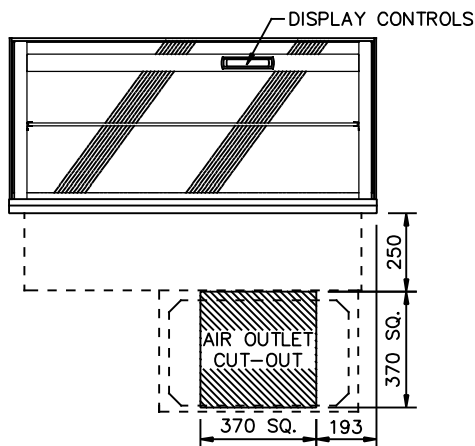
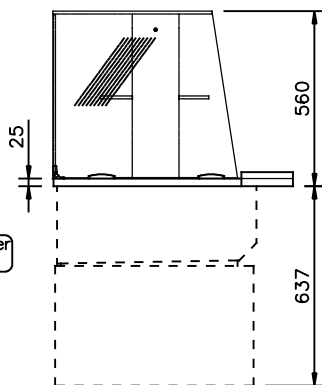

REAR ELEVATION



CUSTOMER & OPERATOR SIDE FASCIA PANELS MUST BE REMOVABLE FOR MAINTENANCE ACCESS
SUPPLIED WITH 400mm SQ. STAINLESS STEEL AIR INLET/OUTLET GRILLES

PRODUCT RANGE: MANHATTAN
DESC.: 3-1Gn ASSISTED SERVICE COLD DELI
OPTION: INTEGRAL REFRIGERATION

ID CODE: MCDL3-GO
OPTION CODE:

counterline 

RANGLES RD, KNOWSLEY BUSINESS PARK, MERSEYSIDE L34 9HZ.

Tel: 0151 548 2211

Fax: 0151 549 2179

ELECTRICAL INFO: 13A, 230V, 2.0KW

WEIGHT: 125Kg

ISSUE:

1



SCALE: 1:25 @ A4

1

2

© COPYRIGHT COUNTERLINE LTD FEB 2007