

A
B
C
D
E
F

FRONT ELEVATION

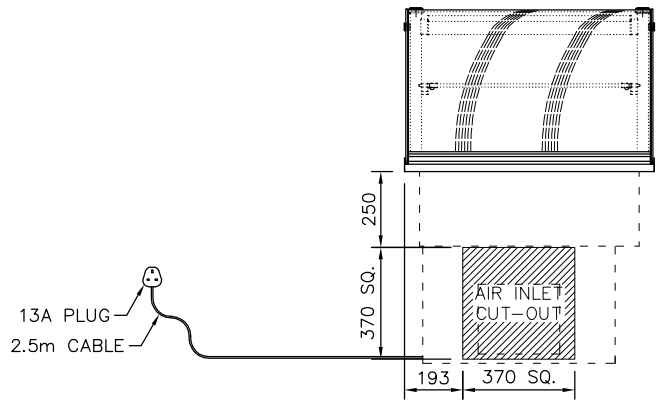

PLAN VIEW

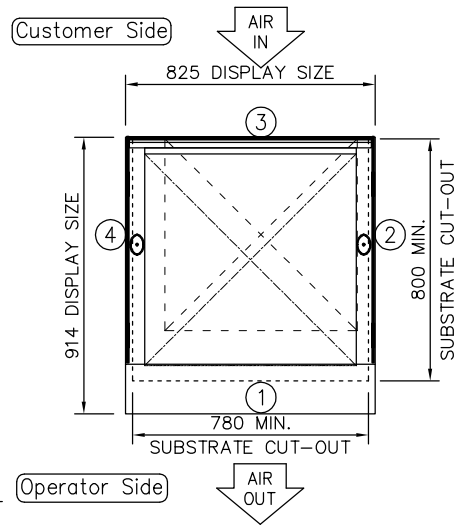

NOTE:
IF DISPLAY IS TO BE FLUSH MOUNTED INTO WORKTOP, ADD 4 - 6mm TO DISPLAY SIZES FOR WORKTOP CUT-OUT

REAR ELEVATION

L.H. END ELEVATION

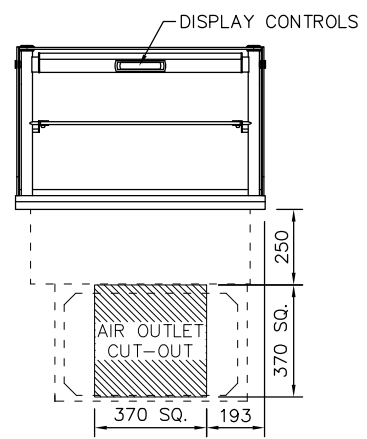
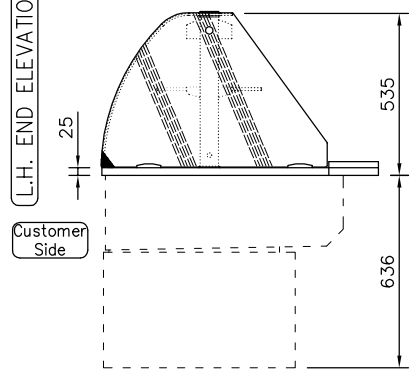

CUSTOMER & OPERATOR SIDE FASCIA PANELS MUST BE REMOVABLE FOR MAINTENANCE ACCESS
SUPPLIED WITH 400mm SQ. STAINLESS STEEL AIR INLET/OUTLET GRILLES

PRODUCT RANGE: idesign
DESC.: 2-1Gn ASSISTED SERVICE COLD WIDE DELI
OPTION: INTEGRAL REFRIGERATION (3-1)



RANDES RD, KNOWSLEY BUSINESS PARK, MERSEYSIDE L34 9HZ.
Tel: 0151 548 2211 Fax: 0151 549 2179

ID CODE: ICWDL2-GO
OPTION CODE:

ELECTRICAL INFO: 13A, 230V, 1.7KW		WEIGHT: 105Kg
ISSUE: 1		SCALE: 1:25 @ A4