

A

B

C

D

E

F

FRONT ELEVATION

PLAN VIEW

REAR ELEVATION

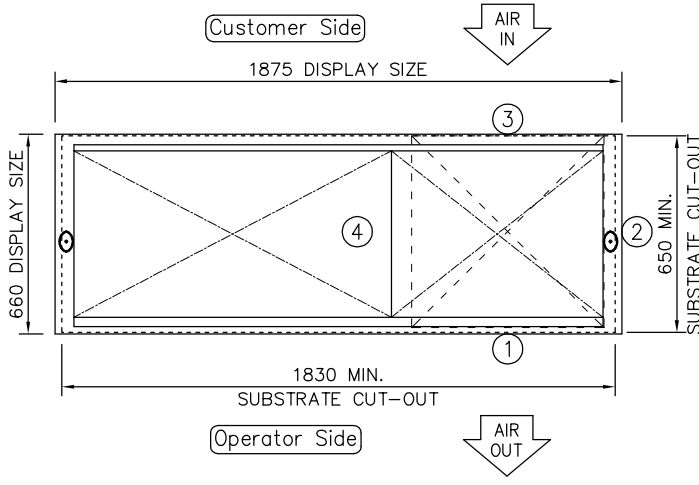
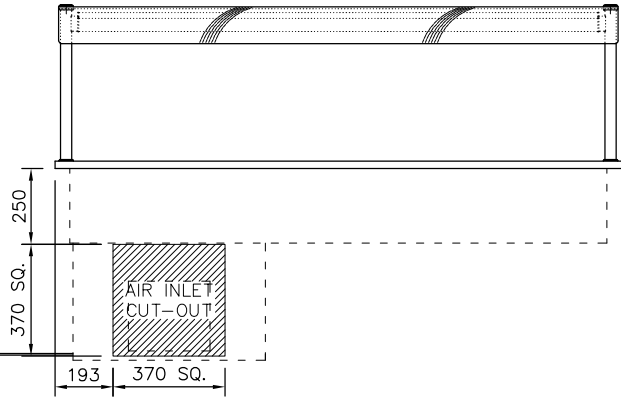
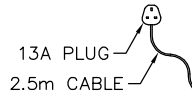

NOTE:
IF DISPLAY IS TO BE FLUSH
MOUNTED INTO WORKTOP,
ADD 4 - 6mm TO DISPLAY
SIZES FOR WORKTOP CUT-OUT

L.H. END ELEVATION

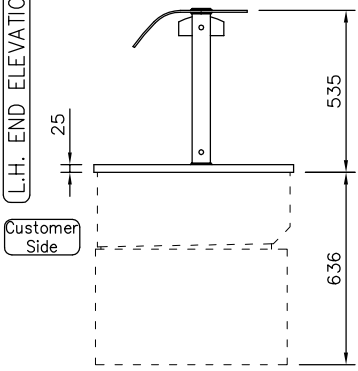

DISPLAY CONTROLS

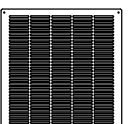
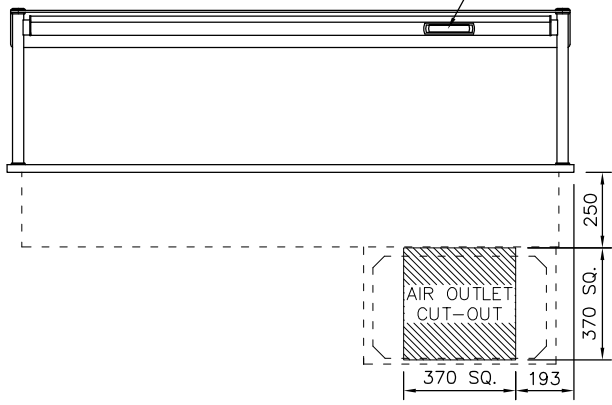

CUSTOMER & OPERATOR SIDE FASCIA
PANELS MUST BE REMOVABLE FOR
MAINTENANCE ACCESS
SUPPLIED WITH 400mm SQ. STAINLESS
STEEL AIR INLET/OUTLET GRILLES

PRODUCT RANGE:	idesign
DESC.:	5-1Gn SELF HELP COLD WELL
OPTION:	INTEGRAL REFRIGERATION (3-1)
ID CODE:	ICW5-GO
OPTION CODE:	

counterline 

RANDES RD, KNOWSLEY BUSINESS PARK, MERSEYSIDE L34 9HZ.
Tel: 0151 548 2211 Fax: 0151 549 2179

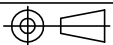
ELECTRICAL INFO:	13A, 230V, 2.3KW	WEIGHT:	141Kg
ISSUE:	1		SCALE: 1:25 @ A4