

FRONT ELEVATION

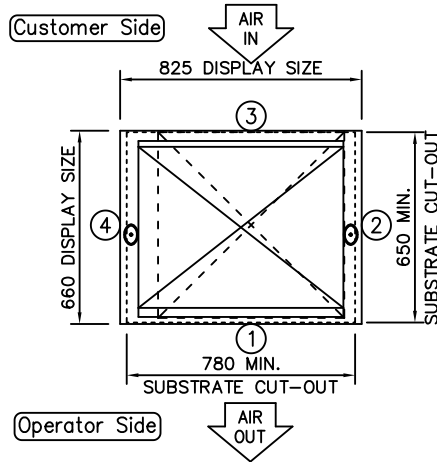

PLAN VIEW

NOTE:  
IF DISPLAY IS TO BE FLUSH MOUNTED INTO WORKTOP, ADD 4 - 6mm TO DISPLAY SIZES FOR WORKTOP CUT-OUT

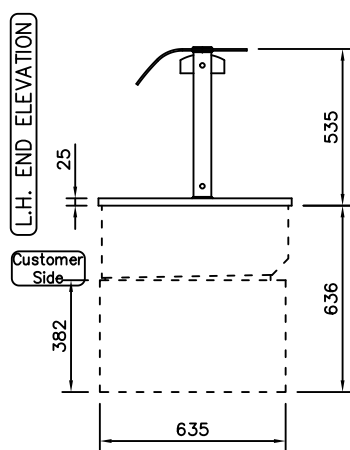

L.H. END ELEVATION

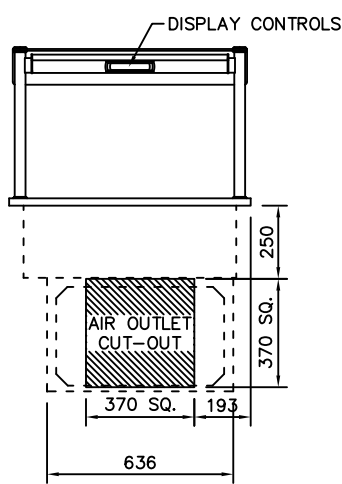

REAR ELEVATION

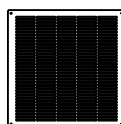
 CUSTOMER & OPERATOR SIDE FASCIA PANELS MUST BE REMOVABLE FOR MAINTENANCE ACCESS  
SUPPLIED WITH 400mm SQ. STAINLESS STEEL AIR INLET/OUTLET GRILLES

PRODUCT RANGE: idesign  
DESC.: 2-1Gn SELF HELP COLD WELL

OPTION: INTEGRAL REFRIGERATION (3-1)

ID CODE: ICW2-GO

OPTION CODE:

**counterline** 

RANDES RD, KNOWSLEY BUSINESS PARK, MERSEYSIDE L34 9HZ.

Tel: 0151 548 2211

Fax: 0151 549 2179

ELECTRICAL INFO: 13A, 230V, 1.7KW

WEIGHT: 91Kg

ISSUE:

1

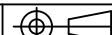

SCALE: 1:25 @ A4