

A

FRONT ELEVATION

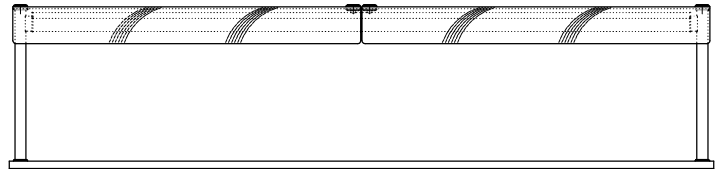

B

13A PLUG
2.5m CABLE

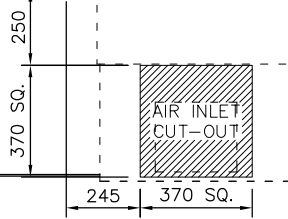

C

PLAN VIEW

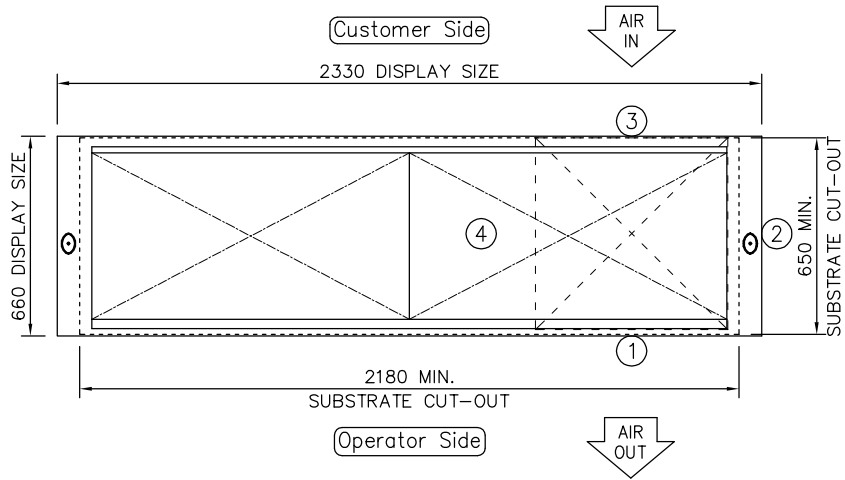

NOTE:
IF DISPLAY IS TO BE FLUSH
MOUNTED INTO WORKTOP,
ADD 4 - 6mm TO DISPLAY
SIZES FOR WORKTOP CUT-OUT

D

REAR ELEVATION

L.H. END ELEVATION

Customer Side

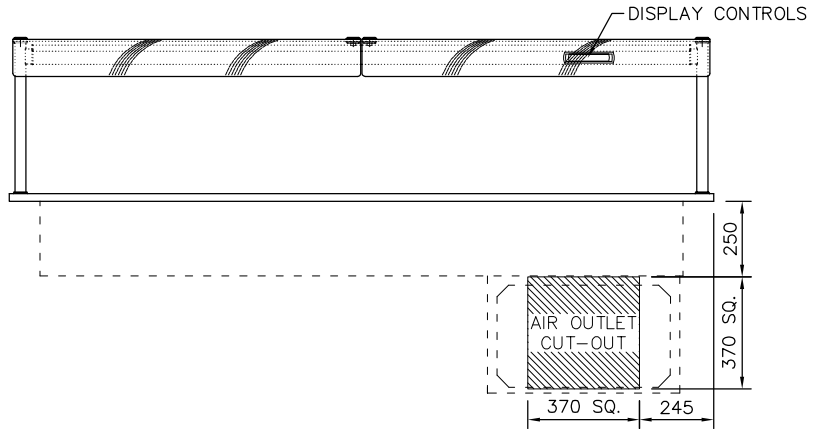
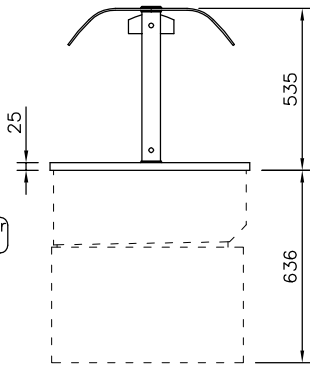

CUSTOMER & OPERATOR SIDE FASCIA
PANELS MUST BE REMOVABLE FOR
MAINTENANCE ACCESS
SUPPLIED WITH 400mm SQ. STAINLESS
STEEL AIR INLET/OUTLET GRILLES

F

PRODUCT RANGE: idesign
DESC.: 6-1Gn SELF HELP COLD ISLAND WEL

OPTION: INTEGRAL REFRIGERATION (3-1)

ID CODE: ICIW6-GO

OPTION
CODE:

counterline 

RANDES RD, KNOWSLEY BUSINESS PARK, MERSEYSIDE L34 9HZ.

Tel: 0151 548 2211

Fax: 0151 549 2179

ELECTRICAL INFO: 13A, 230V, 2.3KW

WEIGHT: 165Kg

ISSUE: 1



SCALE: 1:25 @ A4