

A

B

C

D

E

F

FRONT ELEVATION

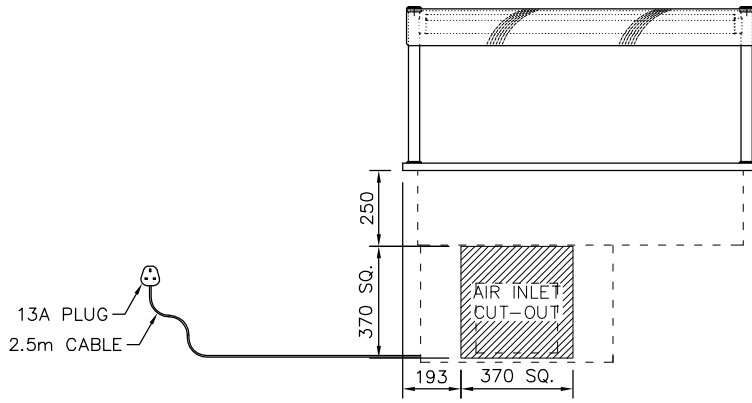

PLAN VIEW

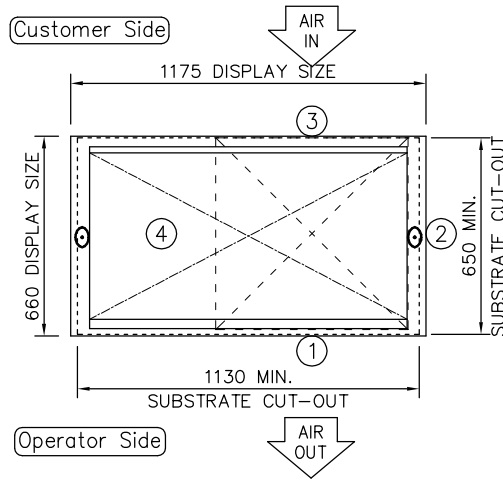

NOTE:
IF DISPLAY IS TO BE FLUSH
MOUNTED INTO WORKTOP,
ADD 4 - 6mm TO DISPLAY
SIZES FOR WORKTOP CUT-OUT

L.H. END ELEVATION

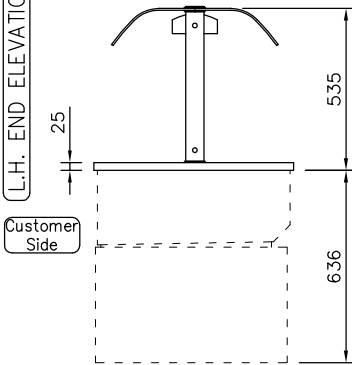

REAR ELEVATION

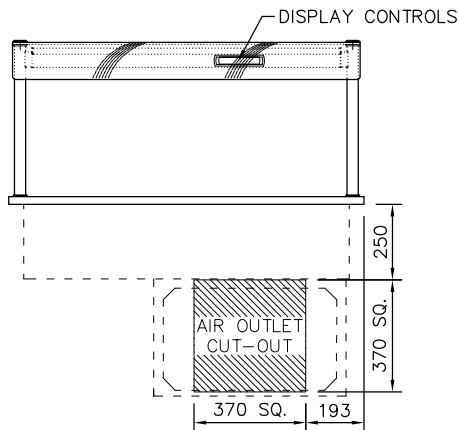

CUSTOMER & OPERATOR SIDE FASCIA
PANELS MUST BE REMOVABLE FOR
MAINTENANCE ACCESS
SUPPLIED WITH 400mm SQ. STAINLESS
STEEL AIR INLET/OUTLET GRILLES

PRODUCT RANGE: idesign
DESC.: 3-1Gn SELF HELP COLD ISLAND WELL
OPTION: INTEGRAL REFRIGERATION (3-1)
ID CODE: ICIW3-GO
OPTION CODE:

counterline

RANDLES RD, KNOWSLEY BUSINESS PARK, MERSEYSIDE L34 9HZ.

Tel: 0151 548 2211

Fax: 0151 549 2179

ELECTRICAL INFO: 13A, 230V, 2.0KW

WEIGHT: 118Kg

ISSUE: 1

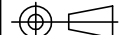

SCALE: 1:25 @ A4