

A
B
C
D
E
F

FRONT ELEVATION

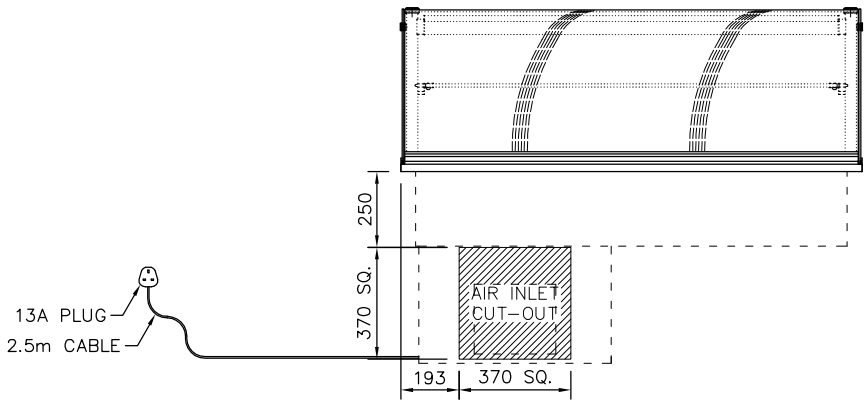

PLAN VIEW

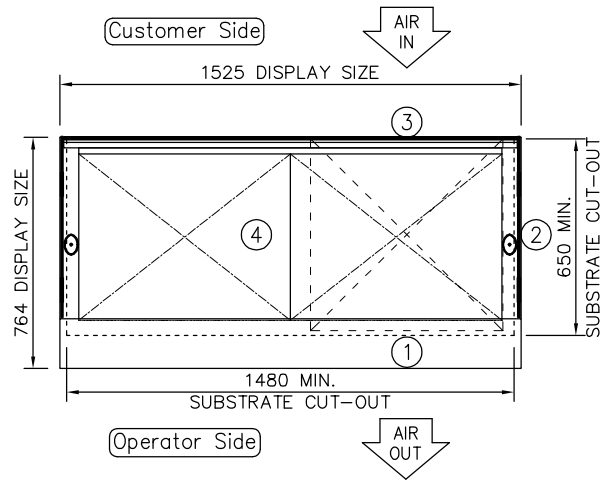

NOTE:
IF DISPLAY IS TO BE FLUSH
MOUNTED INTO WORKTOP,
ADD 4 - 6mm TO DISPLAY
SIZES FOR WORKTOP CUT-OUT

REAR ELEVATION

L.H. END ELEVATION

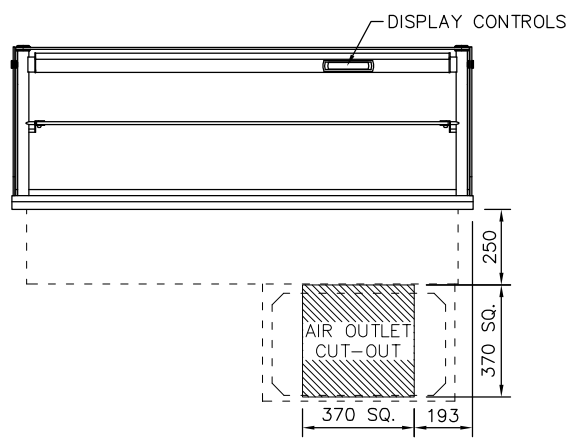
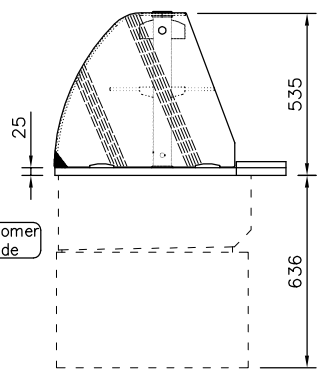

CUSTOMER & OPERATOR SIDE FASCIA
PANELS MUST BE REMOVABLE FOR
MAINTENANCE ACCESS
SUPPLIED WITH 400mm SQ. STAINLESS
STEEL AIR INLET/OUTLET GRILLES

PRODUCT RANGE:	idesign
DESC.:	4-1Gn ASSISTED SERVICE COLD DELI
OPTION:	INTEGRAL REFRIGERATION (3-1)
ID CODE:	ICDL4-GO
OPTION CODE:	

counterline 

RANDLES RD, KNOWSLEY BUSINESS PARK, MERSEYSIDE L34 9HZ.
Tel: 0151 548 2211 Fax: 0151 549 2179

ELECTRICAL INFO: 13A, 230V, 2.2KW		WEIGHT: 153Kg
ISSUE:	1	SCALE: 1:25 @ A4