

A
B
C
D
E
F

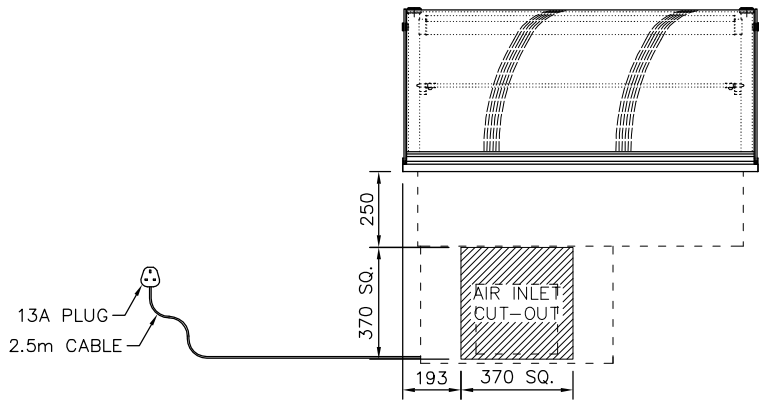

FRONT ELEVATION

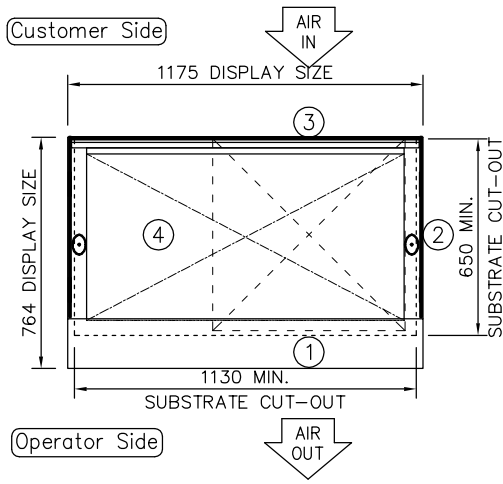

PLAN VIEW

NOTE:
IF DISPLAY IS TO BE FLUSH
MOUNTED INTO WORKTOP,
ADD 4 - 6mm TO DISPLAY
SIZES FOR WORKTOP CUT-OUT

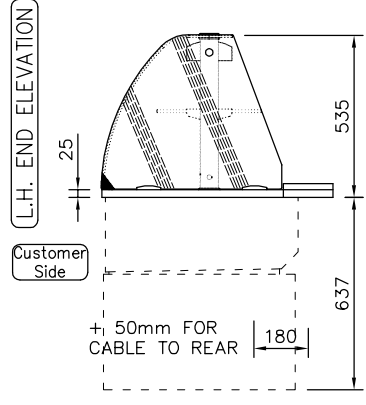

REAR ELEVATION

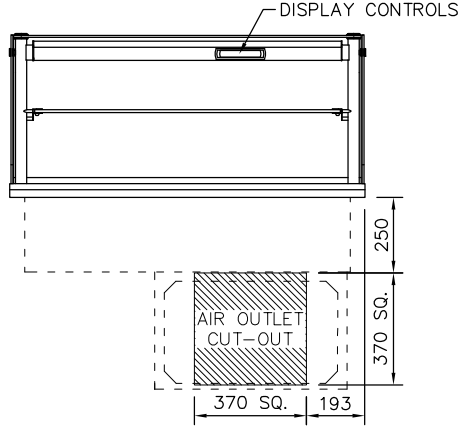

CUSTOMER & OPERATOR SIDE FASCIA
PANELS MUST BE REMOVABLE FOR
MAINTENANCE ACCESS
SUPPLIED WITH 400mm SQ. STAINLESS
STEEL AIR INLET/OUTLET GRILLES

PRODUCT RANGE: idesign
DESC.: 3-1Gn ASSISTED SERVICE COLD
DELI
OPTION: INTEGRAL REFRIGERATION (3-1)



RANDLES RD, KNOWSLEY BUSINESS PARK, MERSEYSIDE L34 9HZ.
Tel: 0151 548 2211 Fax: 0151 549 2179

ID CODE: ICDL3-GO
OPTION CODE:

ELECTRICAL INFO: 13A, 230V, 2.0KW		WEIGHT: 125Kg
ISSUE:	1	SCALE: 1:25 @ A4