

A

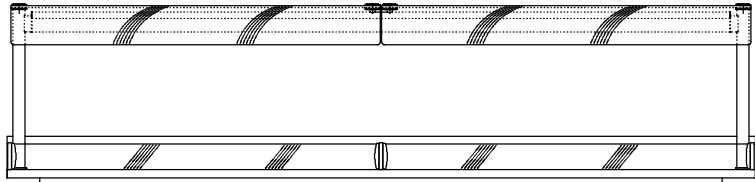

FRONT ELEVATION

B

13A PLUG
2.5m CABLE

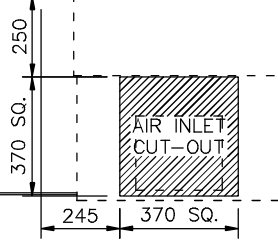

C

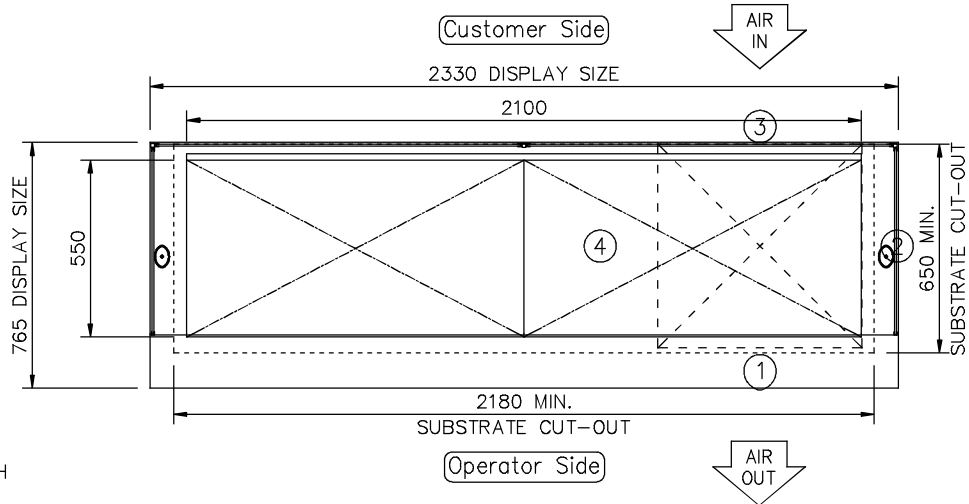

PLAN VIEW

NOTE:
IF DISPLAY IS TO BE FLUSH
MOUNTED INTO WORKTOP,
ADD 4 - 6mm TO DISPLAY
SIZES FOR WORKTOP CUT-OUT

D

L.H. END ELEVATION

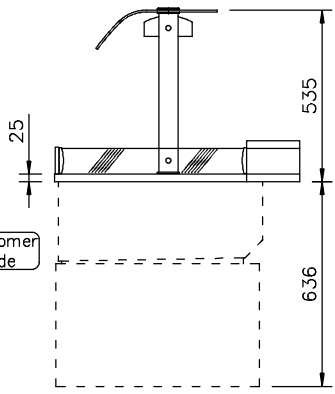

REAR ELEVATION

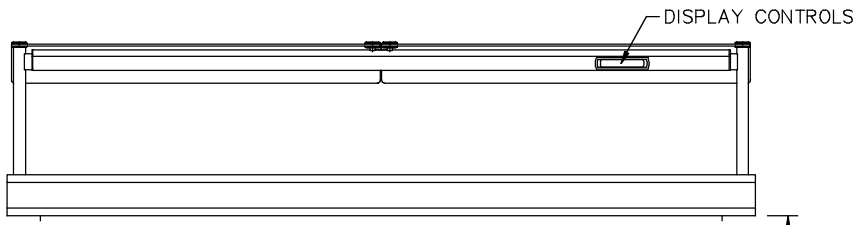

E

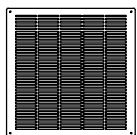

CUSTOMER & OPERATOR SIDE FASCIA
PANELS MUST BE REMOVABLE FOR
MAINTENANCE ACCESS

SUPPLIED WITH 400mm SQ. STAINLESS
STEEL AIR INLET/OUTLET GRILLES

F

PRODUCT RANGE: idesign
DESC.: 6-1Gn SELF HELP COLD DECK
OPTION: INTEGRAL REFRIGERATION (3-1)

ID CODE: ICDK6-GO

OPTION
CODE:

counterline

RANDLES RD, KNOWSLEY BUSINESS PARK, MERSEYSIDE L34 9HZ.

Tel: 0151 548 2211

Fax: 0151 546 6666

ELECTRICAL INFO: 13A, 230V, 2.4KW WEIGHT: 198Kg

ISSUE: 1 SCALE: 1:25 @ A4