

A

B

C

D

E

F

FRONT ELEVATION

PLAN VIEW

REAR ELEVATION

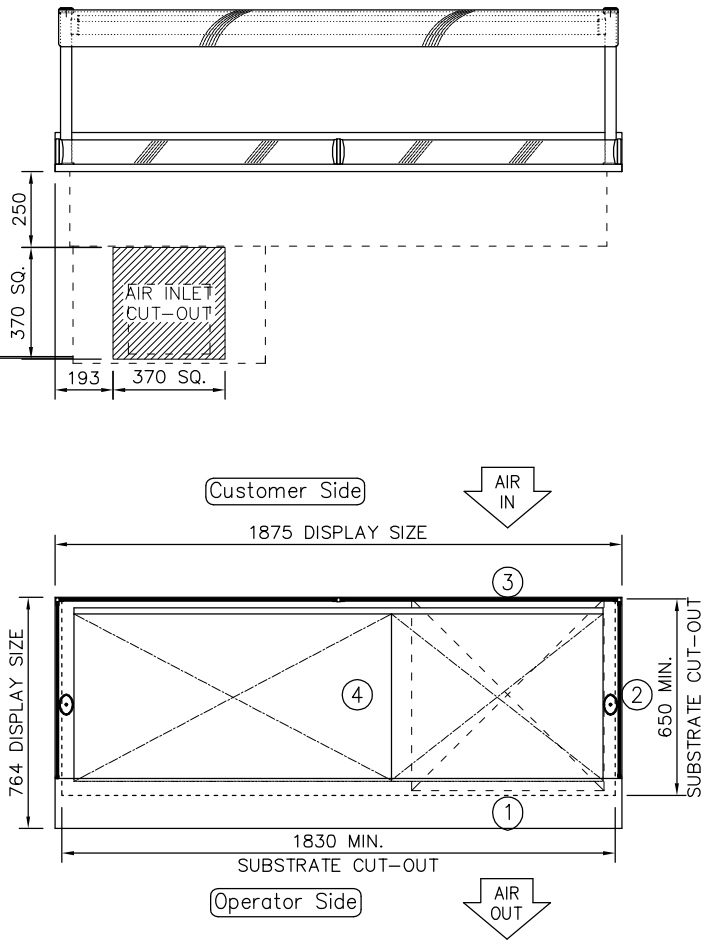
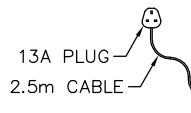

NOTE:  
IF DISPLAY IS TO BE FLUSH  
MOUNTED INTO WORKTOP,  
ADD 4 - 6mm TO DISPLAY  
SIZES FOR WORKTOP CUT-OUT

L.H. END ELEVATION

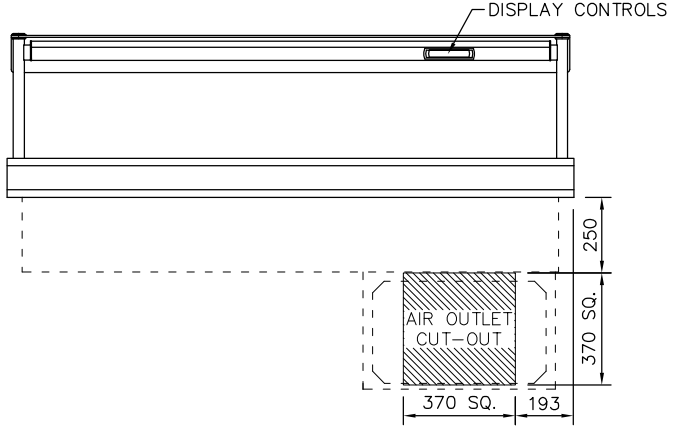
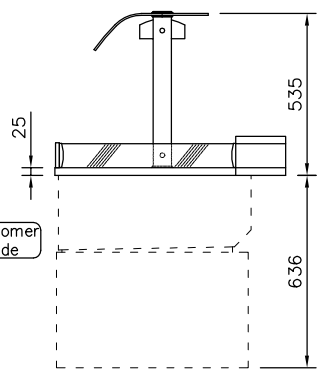

CUSTOMER & OPERATOR SIDE FASCIA  
PANELS MUST BE REMOVABLE FOR  
MAINTENANCE ACCESS

SUPPLIED WITH 400mm SQ. STAINLESS  
STEEL AIR INLET/OUTLET GRILLES

PRODUCT RANGE: idesign  
DESC.: 5-1Gn SELF HELP COLD DECK  
OPTION: INTEGRAL REFRIGERATION (3-1)

ID CODE: ICDK5-GO  
OPTION CODE:

**counterline**

RANGLES RD, KNOWSLEY BUSINESS PARK, MERSEYSIDE L34 9HZ.  
Tel: 0151 548 2211 Fax: 0151 549 2179

ELECTRICAL INFO: 13A, 230V, 2.3KW WEIGHT: 180.8Kg

ISSUE: 1 SCALE: 1:25 @ A4