

A  
B  
C  
D  
E  
F

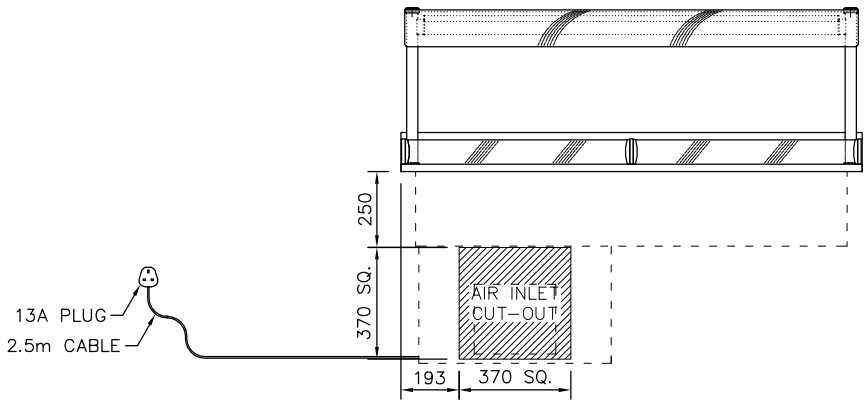

FRONT ELEVATION

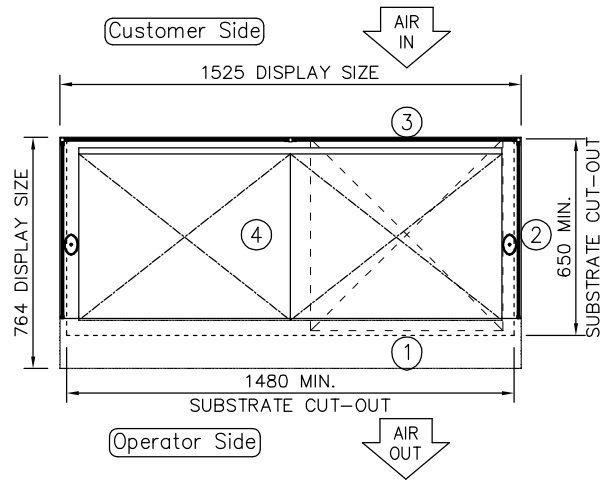

PLAN VIEW

NOTE:  
IF DISPLAY IS TO BE FLUSH  
MOUNTED INTO WORKTOP,  
ADD 4 - 6mm TO DISPLAY  
SIZES FOR WORKTOP CUT-OUT

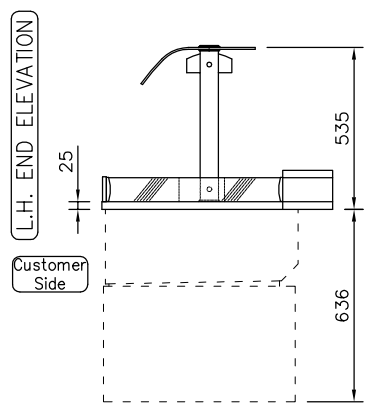

REAR ELEVATION

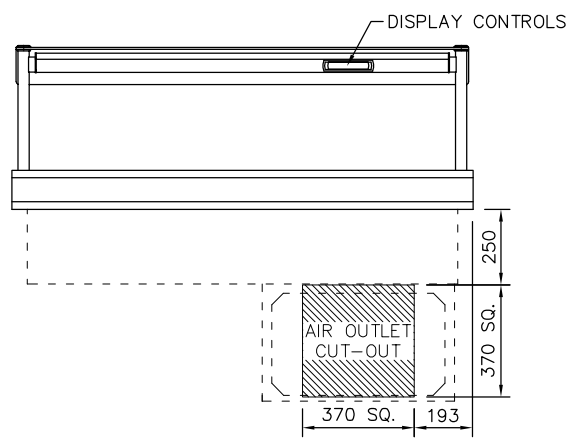

CUSTOMER & OPERATOR SIDE FASCIA  
PANELS MUST BE REMOVABLE FOR  
MAINTENANCE ACCESS  
SUPPLIED WITH 400mm SQ. STAINLESS  
STEEL AIR INLET/OUTLET GRILLES

PRODUCT RANGE:	idesign
DESC.:	4-1Gn SELF HELP COLD DECK
OPTION:	INTEGRAL REFRIGERATION (3-1)
ID CODE:	ICDK4-GO
OPTION CODE:	



RANDES RD, KNOWSLEY BUSINESS PARK, MERSEYSIDE L34 9HZ.  
Tel: 0151 548 2211 Fax: 0151 549 2179

ELECTRICAL INFO: 13A, 230V, 2.2KW		WEIGHT: 167.8Kg
ISSUE:	1	SCALE: 1:25 @ A4