

A
B
C
D
E
F

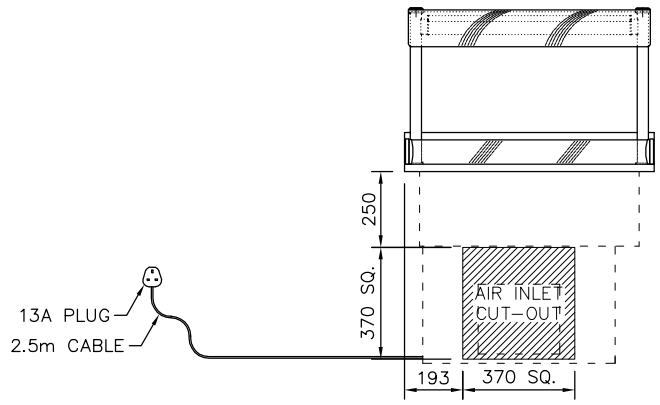

FRONT ELEVATION

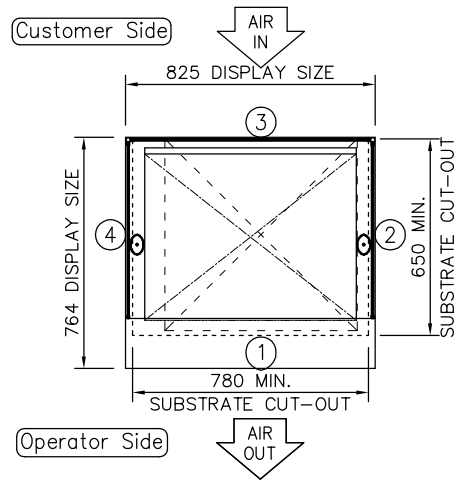

PLAN VIEW

NOTE:
IF DISPLAY IS TO BE FLUSH
MOUNTED INTO WORKTOP,
ADD 4 - 6mm TO DISPLAY
SIZES FOR WORKTOP CUT-OUT

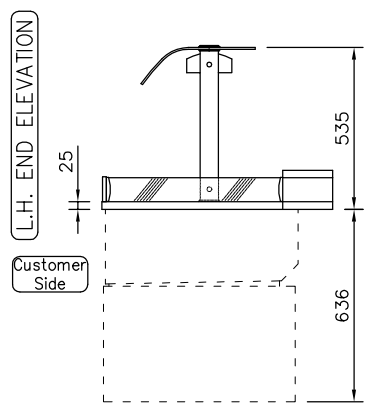

L.H. END ELEVATION

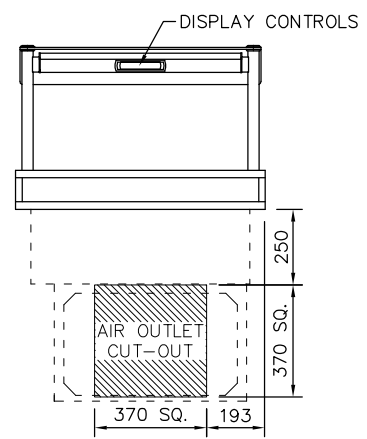

REAR ELEVATION



CUSTOMER & OPERATOR SIDE FASCIA
PANELS MUST BE REMOVABLE FOR
MAINTENANCE ACCESS
SUPPLIED WITH 400mm SQ. STAINLESS
STEEL AIR INLET/OUTLET GRILLES

PRODUCT RANGE:	idesign
DESC.:	2-1Gn SELF HELP COLD DECK
OPTION:	INTEGRAL REFRIGERATION (3-1)
ID CODE:	ICDK2-GO
OPTION CODE:	



RANDLES RD, KNOWSLEY BUSINESS PARK, MERSEYSIDE L34 9HZ.
Tel: 0151 548 2211 Fax: 0151 549 2179

ELECTRICAL INFO:	13A, 230V, 1.7KW	WEIGHT:	123.5Kg
ISSUE:	1	SCALE:	1:25 @ A4