

A  
B  
C  
D  
E  
F

FRONT ELEVATION

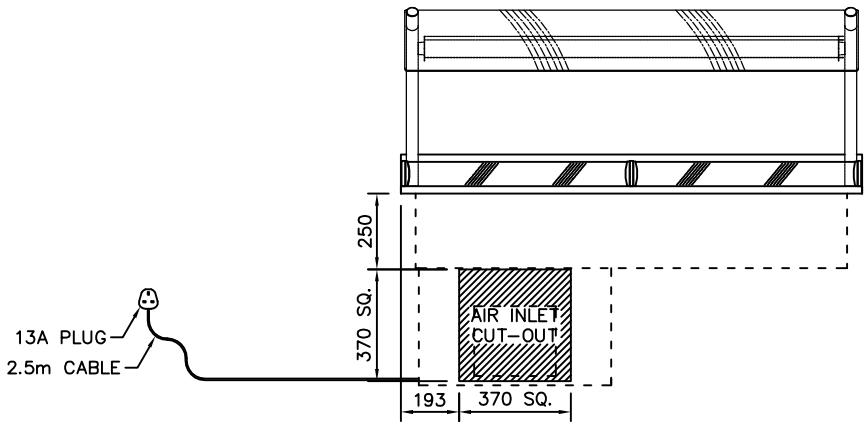

PLAN VIEW

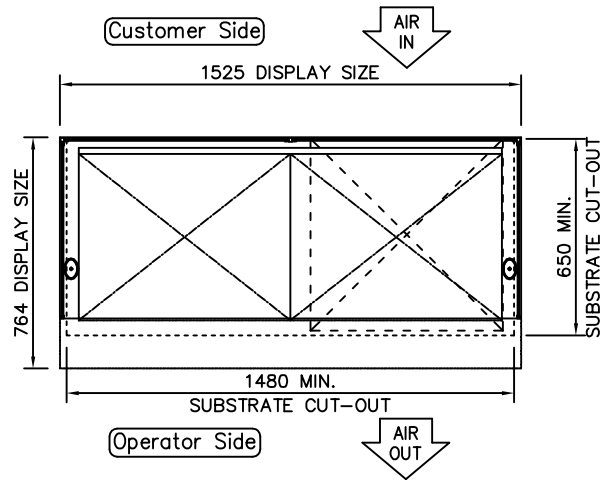

NOTE:  
IF DISPLAY IS TO BE FLUSH  
MOUNTED INTO WORKTOP,  
ADD 4 - 6mm TO DISPLAY  
SIZES FOR WORKTOP CUT-OUT

REAR ELEVATION

L.H. END ELEVATION

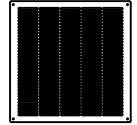
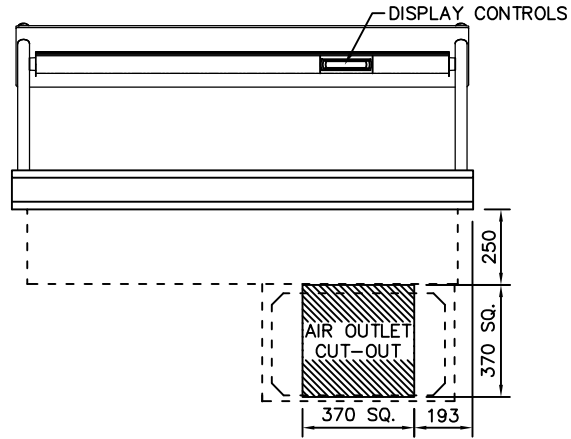
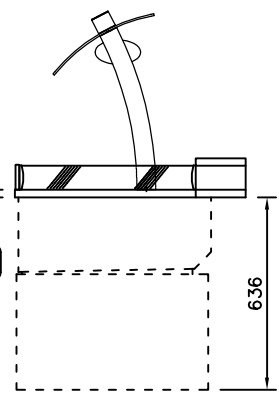

CUSTOMER & OPERATOR SIDE FASCIA  
PANELS MUST BE REMOVABLE FOR  
MAINTENANCE ACCESS  
SUPPLIED WITH 400mm SQ. STAINLESS  
STEEL AIR INLET/OUTLET GRILLES

PRODUCT RANGE: DA VINCI  
DESC.: 4-1Gn SELF HELP COLD DECK

OPTION: INTEGRAL REFRIGERATION

ID CODE: DCDK4-GO

OPTION CODE:



RANDES RD, KNOWSLEY BUSINESS PARK, MERSEYSIDE L34 9HZ.  
Tel: 0151 548 2211 Fax: 0151 549 2179

ELECTRICAL INFO: 13A, 230V, 2.2KW WEIGHT: 167.8Kg

ISSUE: 1 SCALE: 1:25 @ A4