

A

B

C

D

E

F

FRONT ELEVATION

PLAN VIEW

REAR ELEVATION

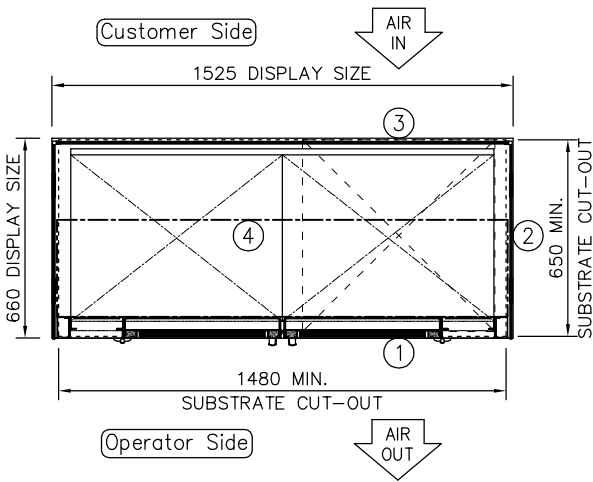
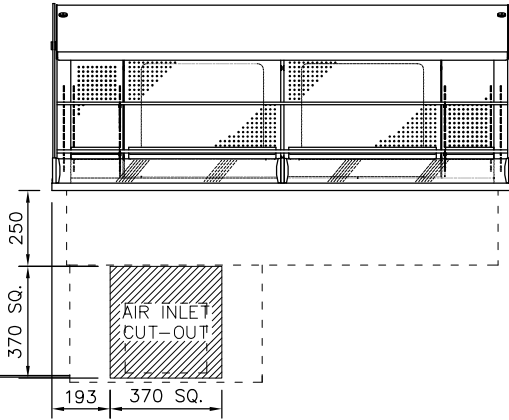
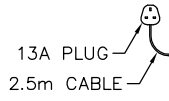

NOTE:  
IF DISPLAY IS TO BE FLUSH MOUNTED INTO WORKTOP,  
ADD 4 - 6mm TO DISPLAY SIZES FOR WORKTOP CUT-OUT

L.H. END ELEVATION

Customer Side

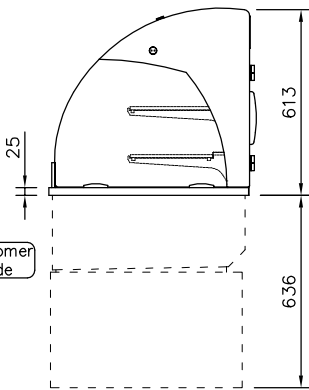

DISPLAY CONTROLS

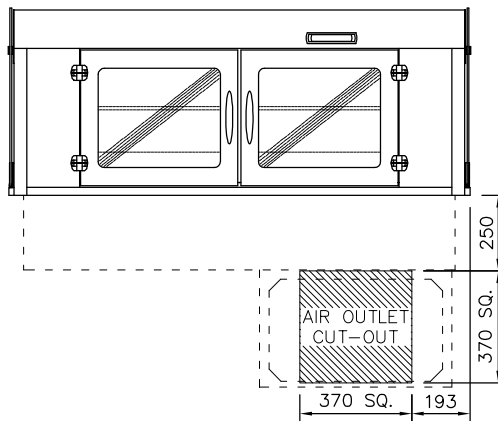

CUSTOMER & OPERATOR SIDE FASCIA PANELS MUST BE REMOVABLE FOR MAINTENANCE ACCESS  
SUPPLIED WITH 400mm SQ. STAINLESS STEEL AIR INLET/OUTLET GRILLES

PRODUCT RANGE: idesign  
DESC.: 4-1Gn SELF HELP COLD MULTIDECK  
3 TIER ADJUSTABLE SHELF+DOORS  
OPTION: INTEGRAL REFRIGERATION (3-1)

ID CODE: DC2ASMD4-GO  
OPTION CODE:

counterline

RANDLES RD, KNOWSLEY BUSINESS PARK, MERSEYSIDE L34 9HZ.

Tel: 0151 548 2211

Fax: 0151 549 2179

ELECTRICAL INFO: 13A, 230V, 3.0KW

WEIGHT: 204Kg

ISSUE: 1



SCALE: 1:25 @ A4